

ОЧАСТКА



ОСНАСТКА

содержание



Руководство по подбору инструмента	G4
DIN69871	G8
HSK	G33
BT-MAS	G62
DIN2080	G89
C-ADAPTER	G100
Цилиндрический хвостовик и конус Морзе	G113
Высокоскоростные шпиндели Turphoon	G130
Цанги	G138
Запчасти и принадлежности	G166
Технические данные	G180

Система обозначений



➤ Биение



➤ Твердость поверхности

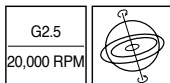

➤ Класс точности балансировки



➤ Класс конуса оправки



➤ Качество обработки поверхности



➤ Страница технического руководства



➤ Цанги ER



➤ Цанги TSK



➤ Цанги ST/TCH



➤ Штревель



➤ Регулировочный винт

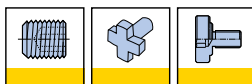

➤ Зажимной винт



➤ Страница ER 32 SRF



➤ Гайка



➤ Адаптер под метчики



➤ Трубка для охлаждения



➤ Ключ для трубки охлаждения

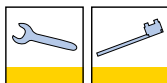

➤ Ключ



➤ Переходное кольцо



➤ Устройство индукционного нагрева



➤ Устройство электрического нагрева

* для нескладских позиций: Поставляется в случае наличия.
Если нет на складе, применяется MOQ (Минимальное количество заказа).



Руководство по подбору инструмента

Оснастка

Фрезерный патрон

DIN69871 G17
HSK G42
BT MAS-403 G71
DIN2080 G92



Цанга (CSR) G156



Хвостовик ST G114-G118

Цанга (ER) G140-G150



GTIN Цанга G163-G164



Цанговый патрон

DIN69871 G11-G13
HSK G36-G41
BT MAS-403 G65-G67
DIN2080 G91
C-ADAPTER G102-G103
Хвостовик ST G114-G118



Цанга (ER) G140-G150



GTIN Цанга G163-G164

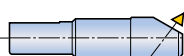

Цанговый патрон TSK

DIN69871 G14
HSK G41
BT MAS-403 G68



TSK Цанга G151-G153



T-SHRINK патрон

DIN69871 G21
HSK G45-G47
BT MAS-403 G75
C-ADAPTER G110



DIN69871 G22
HSK G48-G50
BT MAS-403 G76
Хвостовик ST G124



T-НУСНИК патрон

DIN69871 G23
HSK G51-G52
BT MAS-403 G77-G78



THC Цанга G154-G155



Руководство по подбору инструмента

Оснастка

T-BALANCE

DIN69871 G10
HSK G35
BT MAS-403 G64



Цанга (ER) G140-G150

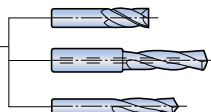

Патрон Weldon для концевых фрез и сверл

DIN69871 G18-G20
HSK G43-G44
BT MAS-403 G72-G74
DIN2080 G93
C-ADAPTER G104-G106

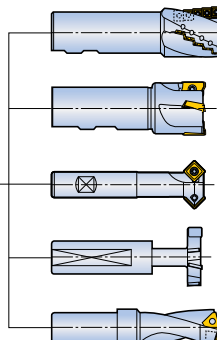

Оправка для торцевых / насадных концевых фрез

DIN69871 G24-G25
HSK G53-G55, G57
BT MAS-403 G80-G82
DIN2080 G94-G95
C-ADAPTER G107

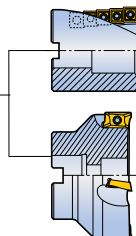

Комбинированные оправки для торцевых фрез / насадных концевых фрез

DIN69871 G26
HSK G56
BT MAS-403 G83
DIN2080 G96
C-ADAPTER G108

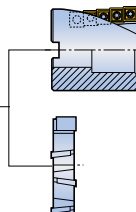

Оправка для дисковых фрез

DIN69871 G28
BT MAS-403 G79

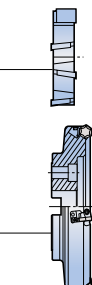

Центрирующая оправка

DIN2080 G99



Руководство по подбору инструмента

Оснастка

Переходная оправка

DIN69871 G31
BT MAS-403 G86

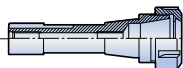
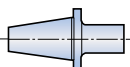

Оправка с конусом Морзе

DIN69871 G29-G30
BT MAS-403 G85-G86
DIN2080 G97-G98



FITBORE

DIN69871 G15
HSK G42
BT MAS-403 G69



Патроны для метчиков (GTI)

DIN69871 G16
BT MAS-403 G70



GTI ER цанговый патрон G125



Цанга (ER) G140-G150



DIN69871 G16
BT MAS-403 G70



Адаптер под метчики G165



Руководство по подбору инструмента

Оснастка

Плавающий патрон для развёртки (GFI)

Хвостовик ST G126



Цанга (ER) G140-G150



T-FLEXTEC

DIN69871 G32

HSK G59-G60

BT MAS-403 G88

C-ADAPTER G111

Хвостовик ST G119-G120



Переходник G121-G123

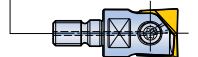
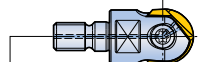

Заготовка

HSK G61

C-ADAPTER G112



Система GYRO (выравнивание по центру)

Хвостовик ST G128-G129



Цанга (ER) G140-G150



DIN69871



DIN69871 Формы А/AD/B/ADB

Стандартный патрон

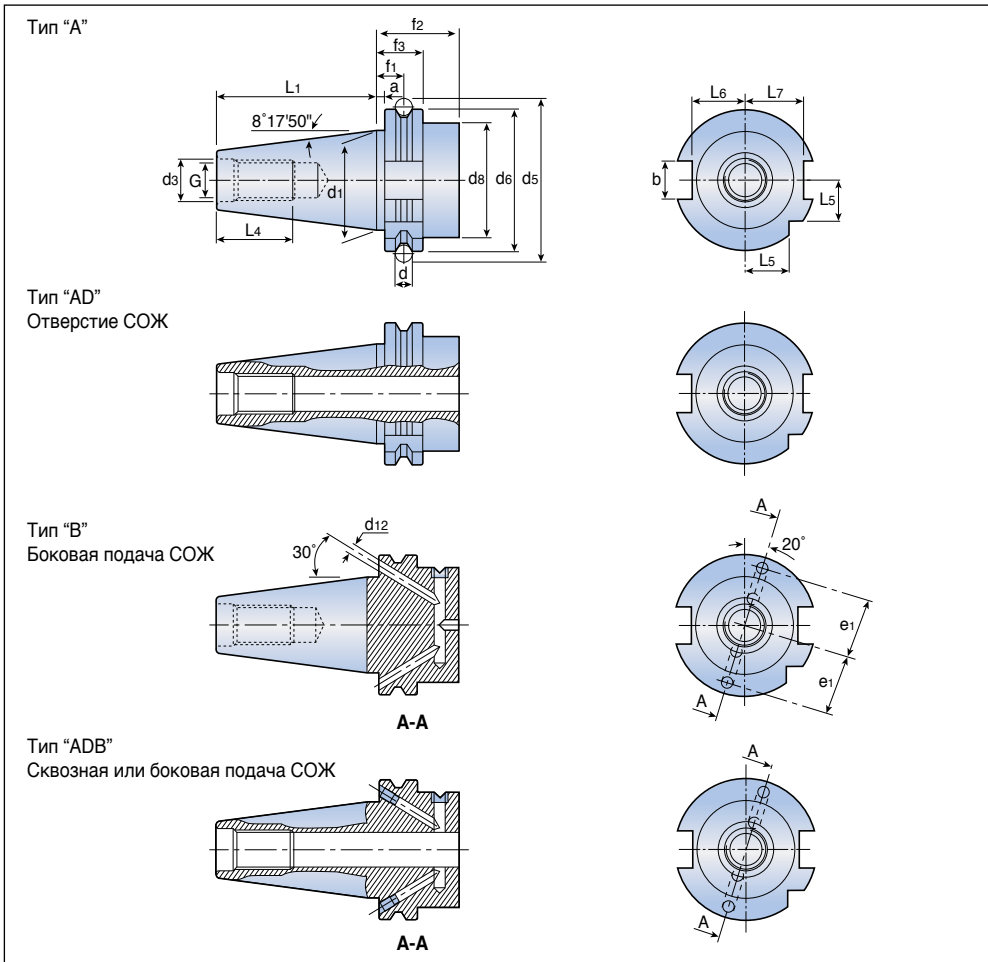

Конус	a ±0.1	b (H12)	d	d1	G	d3 (H7)	d5 ±0.05	d6	dвмакс.	f1 ±0.1
30	3.2	16.1	7	31.75	M12	13	59.30	50.00	45	11.1
40	3.2	16.1	7	44.45	M16	17	72.30	63.55	50	11.1
50	3.2	25.7	7	69.85	M24	25	107.25	97.50	80	11.1

Конус	f2 _{мин.}	f3 -0.1	L1 -0.3	L4 _{мин.}	L5 -0.3	L6 -0.4	L7 -0.4	e1 ±0.1	d12	Конус AT3
30	35	19.1	47.80	24	15.0	16.4	19.0	21	4	0.002
40	35	19.1	68.40	32	18.5	22.8	25.0	27	4	0.003
50	35	19.1	101.75	47	30.0	35.5	37.7	42	6	0.004

* для нескладских позиций: Поставляется в случае наличия.

Если нет на складе, применяется MOQ (Минимальное количество заказа).

DIN69871-ER-SHORT

T-SHORT

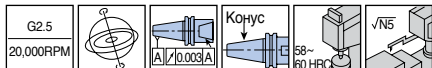
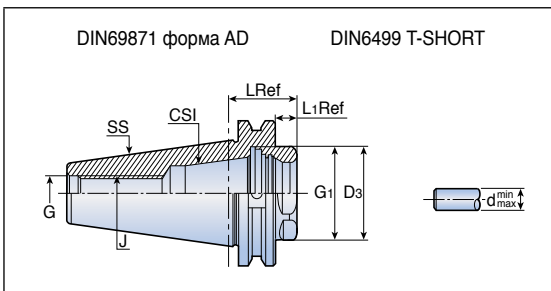

Обозначение	Размеры (мм)									
	SS	CSI	дмин.	дмакс.	D3	L	L1	G	G1	J
DIN69871 40 ER32 SHORT	40	ER32	2.0	20.0	40	28.6	9.5	M16	M40x1.5	M16
DIN69871 50 ER32 SHORT	50	ER32	2.0	20.0	40	28.6	9.5	M24	M40x1.5	M22x1.5
ER40 SHORT	50	ER40	3.0	26.0	50	28.6	9.5	M24	M50x1.5	M28x1.5

DIN69871-ER-CLICK-IN

T-CLICK

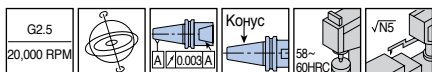
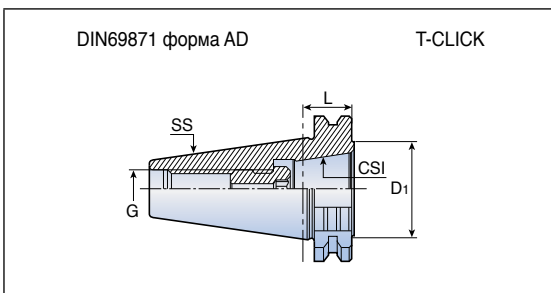

Обозначение	Размеры (мм)				
	SS	CSI	D1	L	G
DIN69871 40 ER32 CLICK-IN	40	SRF32	41	20.1	M16
DIN69871 50 ER32 CLICK-IN	50	SRF32	41	20.1	M24

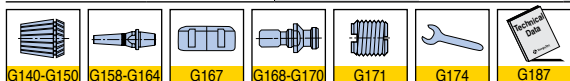

• Затяжное усилие: 24kgxм / 24 кгс*м

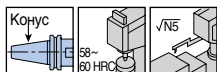
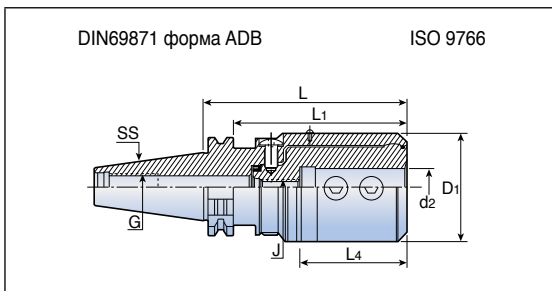

Обозначение	Размеры (мм)							
	SS	d2	D1	L	L1	L4	G	J
FITBORE SKA 40 EM 16 ADB	40	16	72	135.6	116.5	71	M16	M10
EM 20 ADB	40	20	72	135.6	116.5	71	M16	M10
EM 25 ADB	40	25	72	135.6	116.5	71	M16	M10
EM 32 ADB	40	32	72	135.6	116.5	71	M16	M10
EM 40 ADB	40	40	72	135.6	116.5	71	M16	M10
FITBORE SKA 50 EM 16 ADB	50	16	72	115.6	96.5	71	M24	M10
EM 20 ADB	50	20	72	115.6	96.5	71	M24	M10
EM 25 ADB	50	25	72	115.6	96.5	71	M24	M10
EM 32 ADB	50	32	72	115.6	96.5	71	M24	M10
EM 40 ADB	50	40	72	115.6	96.5	71	M24	M10

• Патроны с подводом СОЖ через фланец, имеют дополнительное буквенное обозначение - В

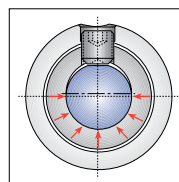

В сечении патрон представляет собой два смещённых кольца. Зажимной винт прижимает хвостовик сверла, при этом патрон упруго деформируется. Контакт происходит более чем по 180°, обеспечивая высокое усилие зажима.

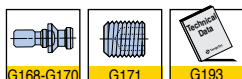

GTI DIN69871-ER

Патрон для метчиков GTI

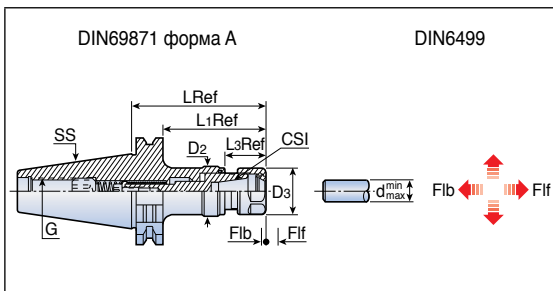
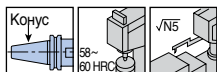

Обозначение	Размеры (мм)													
	SS	CSI	Тармин.	Тармакс.	дмин.	дмакс.	D2	D3	L	L1	L3	Ffb	Flf	G
GTI DIN69871 40 ER 16	40	ER16	M3	M10	0.5	10.0	29.5	28	81.2	62.1	24.6	3	8	M16
	40	ER32	M6	M20	2.0	20.0	56.5	50	112.6	93.5	33.0	4	9	M16
	40	ER40	M6	M28	3.0	26.0	56.5	63	130.6	111.5	51.0	4	9	M24
GTI DIN69871 50 ER 16	50	ER16	M3	M10	0.5	10.0	29.5	28	106.8	87.7	24.6	3	8	M24
	50	ER32	M6	M20	2.0	20.0	56.5	50	115.3	96.2	33.0	4	9	M24
	50	ER40	M6	M28	3.0	26.0	56.5	63	133.3	114.2	51.0	4	9	M24

DIN69871-TC

Патрон для метчика

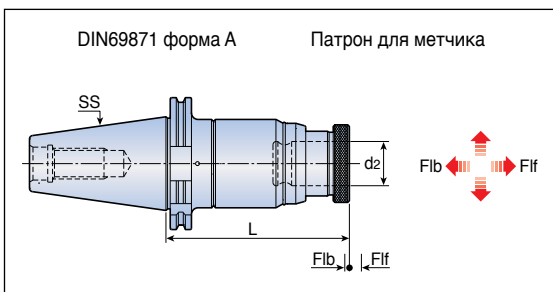
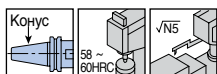

Обозначение	Размеры (мм)							
	SS	Тармин.	Тармакс.	d2	L	Ffb	Flf	Адаптер метчика
DIN69871 40 TC 12-90	40	M3	M12	19	90	6.5	12	TA1
	40	M6	M24	31	142	14.5	13	TA2
DIN69871 50 TC 12-130	50	M3	M12	19	130	6.5	12	TA1
	50	M6	M24	31	142	14.5	13	TA2
	50	M18	M38	48	190	20.0	20	TA3

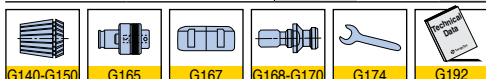

• Система контроля крутящего момента

DIN69871-EM

Патрон Weldon для концевых фрез

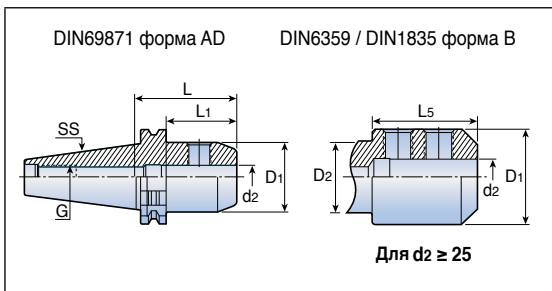
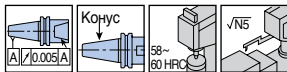

Обозначение	Размеры (мм)								
	SS	d2	D1	D2	L	L1	L5	G	
DIN69871 30	EM 6x50	30	6	25	-	50	30.9	-	M12
	EM 8x50	30	8	28	-	50	30.9	-	M12
	EM 10x50	30	10	35	-	50	30.9	-	M12
	EM 14x63	30	14	44	-	63	43.9	-	M12
	EM 16x63	30	16	48	-	63	43.9	-	M12
	EM 18x72	30	18	50	-	72	52.9	-	M12
	EM 20x72	30	20	52	-	72	52.9	-	M12
DIN69871 40	EM 6x50	40	6	25	-	50	30.9	-	M16
	EM 8x50	40	8	28	-	50	30.9	-	M16
	EM 10x50	40	10	35	-	50	30.9	-	M16
	EM 12x50	40	12	42	-	50	30.9	-	M16
	EM 14x63	40	14	44	-	63	43.9	-	M16
	EM 16x63	40	16	48	-	63	43.9	-	M16
	EM 18x63	40	18	50	-	63	43.9	-	M16
	EM 20x63	40	20	52	-	63	43.9	-	M16
	EM 25x100	40	25	65	49.0	100	80.9	65	M16
	EM 32x100	40	32	71	49.0	100	80.9	65	M16
DIN69871 50	EM 6x63	50	6	25	-	63	43.9	-	M24
	EM 8x63	50	8	28	-	63	43.9	-	M24
	EM 10x63	50	10	35	-	63	43.9	-	M24
	EM 12x63	50	12	42	-	63	43.9	-	M24
	EM 14x63	50	14	44	-	63	43.9	-	M24
	EM 16x63	50	16	48	-	63	43.9	-	M24
	EM 18x63	50	18	50	-	63	43.9	-	M24
	EM 20x63	50	20	52	-	63	43.9	-	M24
	EM 25x80	50	25	65	-	80	60.9	-	M24
	EM 32x100	50	32	72	-	100	80.9	-	M24
	EM 40x100	50	40	90	79.9	100	80.9	43	M24
	EM 50x125	50	50	98	79.9	125	105.9	90	M24

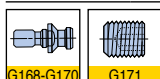

• Патроны с подводом СОЖ через фланец, имеют дополнительное буквенное обозначение - В кроме DIN69871 30

DIN69871-EM-E

Патрон для концевых фрез - Whistle notch

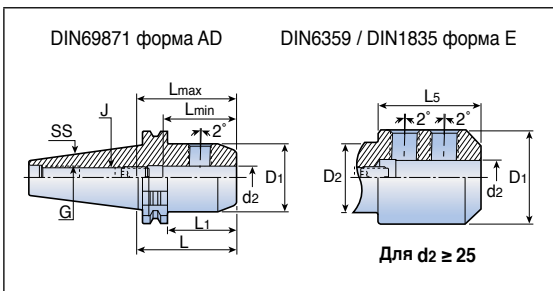
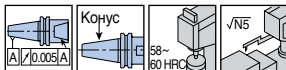

Обозначение	Размеры (мм)											
	SS	d2	D1	D2	L	Lмин.	Lмакс.	L1	L5	G	J	
DIN69871 40	EM 8x50E	40	8	28	-	50	35	45	30.9	-	M16	M6
	EM 10x50E	40	10	35	-	50	39	49	30.9	-	M16	M8
	EM 12x50E	40	12	42	-	50	44	54	30.9	-	M16	M10
	EM 14x63E	40	14	44	-	63	44	54	43.9	-	M16	M10
	EM 16x63E	40	16	48	-	63	47	57	43.9	-	M16	M12
	EM 18x63E	40	18	50	-	63	47	57	43.9	-	M16	M12
	EM 20x63E	40	20	52	-	63	49	59	43.9	-	M16	M16
	EM 25x100E	40	25	64	49	100	54	64	80.9	65	M16	M20x1.5
DIN69871 50	EM 32x100E	40	32	71	49	100	58	68	80.9	65	M16	M20x1.5
	EM 8x63E	50	8	28	-	63	35	45	43.9	-	M24	M6
	EM 10x63E	50	10	35	-	63	39	49	43.9	-	M24	M8
	EM 12x63E	50	12	42	-	63	44	54	43.9	-	M24	M10
	EM 14x63E	50	14	44	-	63	44	54	43.9	-	M24	M10
	EM 16x63E	50	16	48	-	63	47	57	43.9	-	M24	M12
	EM 18x63E	50	18	50	-	63	47	57	43.9	-	M24	M12
	EM 20x63E	50	20	52	-	63	49	59	43.9	-	M24	M16
	EM 25x80E	50	25	65	-	80	54	64	60.9	-	M24	M20x1.5
	EM 32x100E	50	32	72	-	100	58	68	80.9	-	M24	M20x1.5
	EM 40x100E	50	40	90	79	100	68	78	80.9	43	M24	M20x1.5

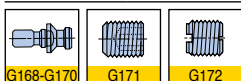

- Регулируемый винт имеет отверстие подачи СОЖ
- Патроны с подводом СОЖ через фланец, имеют дополнительное буквенное обозначение - В

DIN69871-SEMC

Комбинированная оправка для торцевых/насадных и дисковых фрез

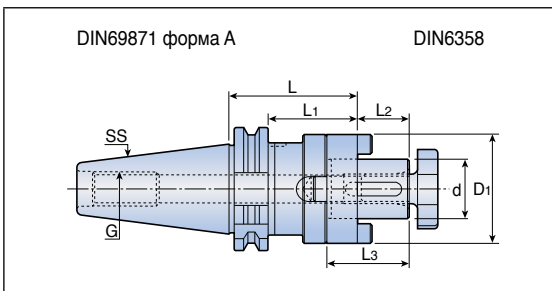
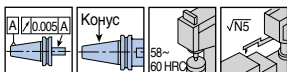

Обозначение	Размеры (мм)							
	SS	d	D1	L	L1	L2	L3	G
DIN69871 30 SEMC 16x50	30	16	32	50	30.9	17	27	M12
	30	22	40	50	30.9	19	31	M12
	30	32	58	30	40.9	24	38	M12
DIN69871 40 SEMC 16x55	40	16	32	55	35.9	17	27	M16
	40	16	32	100	80.9	17	27	M16
	40	22	40	55	35.9	19	31	M16
	40	22	40	100	80.9	19	31	M16
	40	27	48	55	35.9	21	33	M16
	40	27	48	100	80.9	21	33	M16
	40	32	58	60	45.9	24	38	M16
	40	32	58	100	80.9	24	38	M16
	40	40	70	60	40.9	27	41	M16
	40	40	70	100	80.9	27	41	M16
DIN69871 50 SEMC 16x55	50	16	32	55	35.9	17	27	M24
	50	16	32	100	80.9	17	27	M24
	50	22	40	55	35.9	19	31	M24
	50	22	40	100	80.9	19	31	M24
	50	27	48	55	35.9	21	33	M24
	50	27	48	100	80.9	21	33	M24
	50	32	58	55	35.9	24	38	M24
	50	32	58	100	80.9	24	38	M24
	50	40	70	55	35.9	27	41	M24
	50	40	70	10	80.9	27	41	M24
	50	50	90	70	50.9	30	46	M24
	50	50	90	100	80.9	30	46	M24

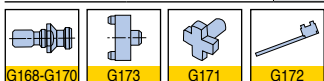

• Ключ не входит в поставку

DIN69871-AD

Переходная оправка

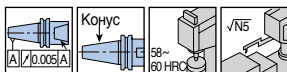
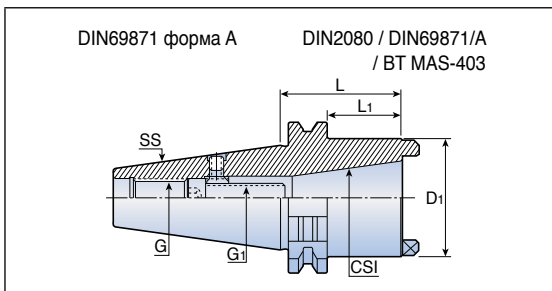

Обозначение	Размеры (мм)						
	SS	CSI	D1	L	L1	G	G1
DIN69871 40 AD DIN2080 30	40	DIN2080 30	50	50	30.9	M16	M12
DIN69871 50 AD BT/SK 40	50	BT/SK 40	66	70	50.9	M24	M16

DIN69871-DC

Оправка для сверлильных патронов

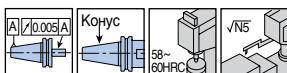
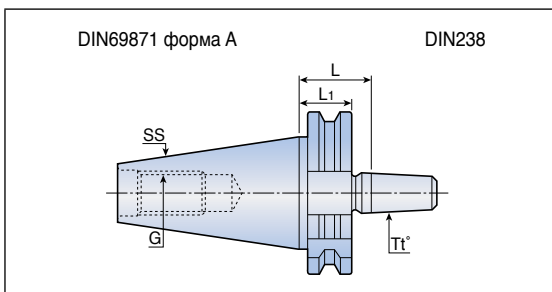

Обозначение	Размеры (мм)				
	SS	Tt°	L	L1	G
DIN69871 30 DC B12x26	30	B12	26	19.1	M12
DIN69871 40 DC B12x26	40	B12	26	19.1	M16
DC B16x26	40	B16	26	19.1	M16
DC B18x26	40	B18	26	19.1	M16
DIN69871 50 DC B16x26	50	B16	26	19.1	M24
DC B18x26	50	B16	26	19.1	M24



• Без сверлильного патрона

HSK



DIN69893 Форма A/E/F

Стандартный патрон

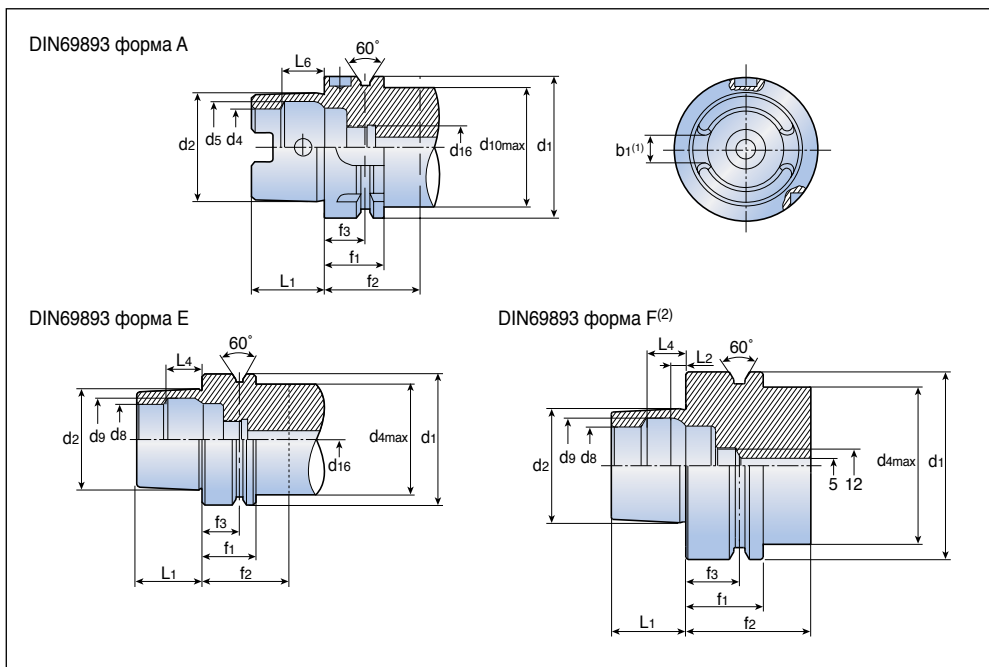

DIN69893 форма A

HSK-A	d1 h10	d2	d4 H10	d5 H11	d10макс.	d16	L1 -0.2	L6 JS10	b1 ±0.04 ⁽¹⁾	f1 -0.1	f2мин.	f3 ±0.1
40	40	30	21	25.5	34	M12x1	20	11.42	8.05	20	35	16
50	50	38	26	32.0	42	M16x1	25	14.13	10.54	26	42	18
63	63	48	34	40.0	53	M18x1	32	18.13	12.54(12.42)	26	42	18
80	80	60	42	50.0	67	M20x1.5	40	22.85	16.04	26	42	18
100	100	75	53	63.0	85	M24x1.5	50	28.56	20.02 (19.9)	29	45	20

• ⁽¹⁾ Размеры, данные в скобках, относятся к b1 только для инструментов HSK A...WH

Эти инструменты отличает возможность точной установки вертикальной позиции режущей кромки (Согласно японскому стандарту ICTM и стандарту ISO 12164/3)

DIN69893 форма E

HSK-E	d1 h10	d2	d4макс.	d8 H10	d9 H11	d16	L1 -0.2	L4 JS10	f1 -0.1	f2мин.	f3 ±0.1
32	32	24	26	17	19.0	M10x1	16	8.92	20	35	16
40	40	30	34	21	25.5	M12x1	20	11.42	20	35	16
50	50	38	42	26	32.0	M16x1	25	14.13	26	42	18
63	63	48	53	34	40.0	M18x1	32	18.13	26	42	18

DIN69893 форма F(2)

HSK-F	d1 h10	d2	d4макс.	d8 H10	d9 H11	L1 -0.2	L2	L4 JS10	f1 -0.1	f2мин.	f3 ±0.1
63	63	38	53	26	32	25	5.0	14.13	26	42	18

• ⁽²⁾ Без поперечного отверстия СОЖ

* для нескладских позиций: Поставляется в случае наличия.

Если нет на складе, применяется MOQ (Минимальное количество заказа).

HSK A-ER-BIN

T-BALANCE

Цанговый патрон ER с балансируемыми кольцами

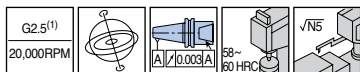
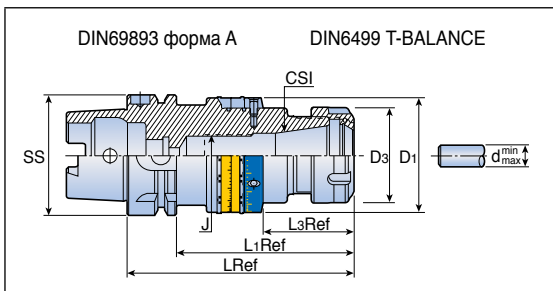

Обозначение	Размеры (мм)									
	SS	CSI	d _{мин.}	d _{макс.}	D ₁	D ₃	L	L ₁	L ₃	J
HSK A 63 ER 16x100 BIN	63	ER16	0.5	10.0	44	28	100	74	45.0	M10
ER 16x160 BIN	63	ER16	0.5	10.0	44	28	160	134	75.0	M10
ER 20x100 BIN	63	ER20	1.0	13.0	44	34	100	74	45.1	M12
ER 20x160 BIN	63	ER20	1.0	13.0	44	34	160	134	86.1	M12
ER 25x100 BIN	63	ER25	1.0	16.0	44	42	100	74	45.2	M16
ER 25x160 BIN	63	ER25	1.0	16.0	44	42	160	134	86.2	M16
ER 32x120 BIN	63	ER32	2.0	20.0	60	50	120	94	48.0	M22x1.5
ER 32x160 BIN	63	ER32	2.0	20.0	60	50	160	134	85.0	M22x1.5

• (1) Значение балансировки

HSK E-ER-BIN

T-BALANCE

Цанговый патрон ER с балансируемыми кольцами

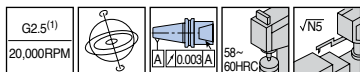
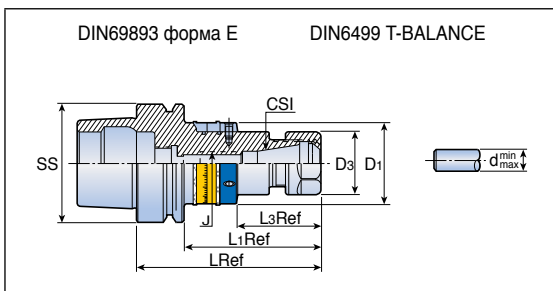

Обозначение	Размеры (мм)									
	SS	CSI	d _{мин.}	d _{макс.}	D ₁	D ₃	L	L ₁	L ₃	J
HSK E 63 ER 16x100 BIN	63	ER16	0.5	10.0	44	28	100	74	45.0	M10
ER 20x100 BIN	63	ER20	1.0	13.0	44	34	100	74	45.1	M12
ER 25x100 BIN	63	ER25	1.0	13.0	44	42	100	74	45.2	M16
ER 32x120 BIN	63	ER32	2.0	20.0	60	50	120	94	48.0	M22x1.5

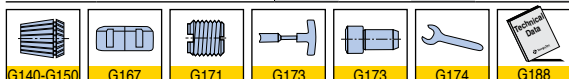

• (1) Значение балансировки

HSK A-ER

Цанговый патрон ER

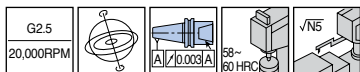
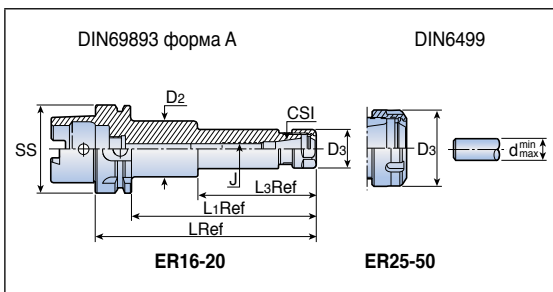

Обозначение	Размеры (мм)										
	SS	CSI	d _{мин.}	d _{макс.}	D ₂	D ₃	L	L ₁	L ₃	J	
HSK A 40	ER 16x60	40	ER16	0.5	10.0	-	28	60	40	-	-
	ER 16x80	40	ER16	0.5	10.0	-	28	80	60	-	M10
	ER 16x100	40	ER16	0.5	10.0	-	28	100	80	-	M10
	ER 25x60	40	ER25	1.0	16.0	32.4	42	60	40	28.0	-
	ER 25x80	40	ER25	1.0	16.0	32.4	42	80	60	28.0	M18x1.5
	ER 25x100	40	ER25	1.0	16.0	32.4	42	100	80	28.0	M16
ER 32x100	40	ER32	2.0	20.0	40.4	50	100	80	31.0	M22x1.5	
HSK A 50	ER 16x100	50	ER16	0.5	10.0	-	28	100	74	-	M10
	ER 16x120	50	ER16	0.5	10.0	-	28	120	94	-	M10
	ER 20x100	50	ER20	1.0	13.0	-	34	100	74	-	M12
	ER 20x120	50	ER20	1.0	13.0	-	34	120	94	-	M12
	ER 25x80	50	ER25	1.0	16.0	32.4	42	80	54	28.0	M8
	ER 25x100	50	ER25	1.0	16.0	41.8	42	100	74	28.5	M16
	ER 32x100	50	ER32	2.0	20.0	40.4	50	100	74	31.0	M22x1.5
	ER 32x120	50	ER32	2.0	20.0	41.8	50	120	94	35.0	M22x1.5
HSK A 63	ER 16x100	63	ER16	0.5	10.0	-	28	100	74	-	M10
	ER 16x120	63	ER16	0.5	10.0	-	28	120	94	-	M10
	ER 16x160	63	ER16	0.5	10.0	40.0	28	160	134	85.6	M10
	ER 20x100	63	ER20	1.0	13.0	-	34	100	74	-	M12
	ER 20x120	63	ER20	1.0	13.0	-	34	120	94	-	M12
	ER 20x160	63	ER20	1.0	13.0	45.0	34	160	134	85.0	M12
	ER 25x80	63	ER25	1.0	16.0	-	42	80	54	-	M8
	ER 25x100	63	ER25	1.0	16.0	-	42	100	74	-	M16
	ER 25x120	63	ER25	1.0	16.0	-	42	120	94	-	M16
	ER 25x160	63	ER25	1.0	16.0	-	42	160	134	-	M16
	ER 32x80	63	ER32	2.0	20.0	40.4	50	80	54	31.0	-
	ER 32x100	63	ER32	2.0	20.0	-	50	100	74	-	M22x1.5
	ER 32x120	63	ER32	2.0	20.0	-	50	120	94	-	M22x1.5
	ER 32x160	63	ER32	2.0	20.0	-	50	160	134	-	M22x1.5
	ER 40x80	63	ER40	3.0	26.0	50.4	63	80	54	34.0	-
	ER 40x100	63	ER40	3.0	26.0	50.4	63	100	74	34.0	M28x1.5
	ER 40x120	63	ER40	3.0	26.0	50.4	63	120	94	34.0	M28x1.5

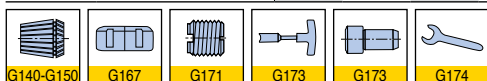

HSK A-ER

Цанговый патрон ER

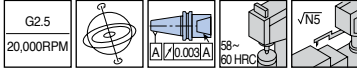
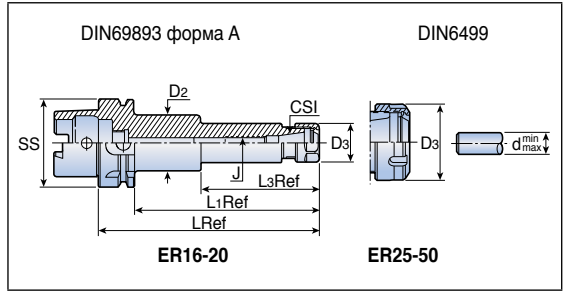

Обозначение	Размеры (мм)									
	SS	CSI	d _{мин.}	d _{макс.}	D ₂	D ₃	L	L ₁	L ₃	J
HSK A 100 ER 16x100⁽¹⁾	100	ER16	0.5	10.0	-	28	100	71	-	M10
ER 16x160⁽¹⁾	100	ER16	0.5	10.0	40	28	160	131	85	M10
ER 20x100⁽¹⁾	100	ER20	1.0	13.0	-	34	100	71	-	M12
ER 20x160⁽¹⁾	100	ER20	1.0	13.0	50	34	160	131	85	M12
ER 25x100⁽¹⁾	100	ER25	1.0	16.0	-	42	100	71	-	M16
ER 25x120⁽¹⁾	100	ER25	1.0	16.0	-	42	120	91	-	M16
ER 25x160⁽¹⁾	100	ER25	1.0	16.0	-	42	160	134	-	M16
ER 32x100⁽¹⁾	100	ER32	2.0	20.0	-	50	100	71	-	M22x1.5
ER 32x120⁽¹⁾	100	ER32	2.0	20.0	-	50	120	91	-	M22x1.5
ER 32x160⁽¹⁾	100	ER32	2.0	20.0	-	50	160	131	-	M22x1.5
ER 40x100⁽¹⁾	100	ER40	3.0	26.0	-	63	100	71	-	M28x1.5
ER 40x120⁽¹⁾	100	ER40	3.0	26.0	-	63	120	91	-	M28x1.5
ER 40x160⁽¹⁾	100	ER40	3.0	26.0	-	63	160	131	-	M28x1.5
ER 50x100⁽¹⁾	100	ER50	10.0	34.0	-	78	100	71	-	M22x1.5

• ⁽¹⁾ Балансировка G6,3 при 12000 об./мин.

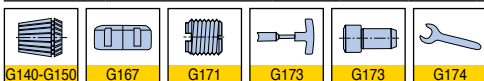

HSK E-ER

Цанговый патрон ER

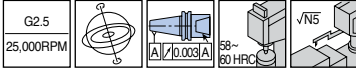
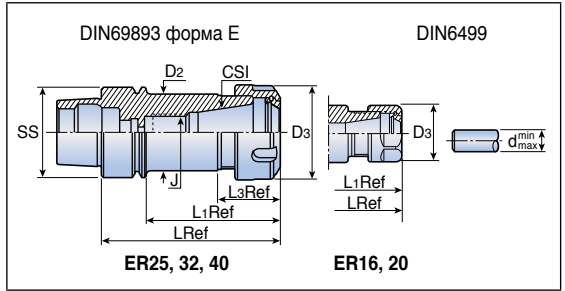

Обозначение	Размеры (мм)										
	SS	CSI	d _{мин.}	d _{макс.}	D2	D3	L	L1	L3	J	
HSK E 32	ER 16x60	32	ER16	0.5	10.0	22.4	28	60	40	21.5	-
	ER 20x60	32	ER20	1.0	13.0	25.4	34	60	40	26.0	-
	ER 25x65	32	ER25	1.0	16.0	25.8	42	65	45	30.0	-
HSK E 40	ER 16x60	40	ER16	0.5	10.0	-	28	60	40	-	-
	ER 16x80	40	ER16	0.5	10.0	-	28	80	60	-	M10
	ER 20x80	40	ER20	1.0	13.0	-	34	80	60	-	M12
	ER 25x80	40	ER25	1.0	16.0	34.0	42	80	60	28.0	M18x1.5
	ER 32x80	40	ER32	2.0	20.0	40.1	50	-	60	31.0	M22x1.5
HSK E 50	ER 16x80	50	ER16	0.5	10.0	-	28	80	54	-	M10
	ER 16x100	50	ER16	0.5	10.0	-	28	100	74	-	M10
	ER 16x100 M⁽¹⁾	50	ER16	0.5	10.0	-	22	100	74	-	M10
	ER 20x80	50	ER20	1.0	13.0	-	34	80	54	-	M12
	ER 25x80	50	ER25	1.0	16.0	32.4	42	80	54	28.0	M16
	ER 32x80	50	ER32	2.0	20.0	40.4	50	80	54	31.0	-
HSK E 63	ER 16x80	63	ER16	0.5	10.0	-	28	80	54	-	M10
	ER 16x100	63	ER16	0.5	10.0	-	28	100	74	-	M10
	ER 20x75	63	ER20	1.0	13.0	-	34	75	49	-	-
	ER 32x80	63	ER32	2.0	20.0	40.4	50	80	54	31.0	-
	ER 32x100	63	ER32	2.0	20.0	-	50	100	75	-	M22x1.5
	ER 40x80	63	ER40	3.0	26.0	-	63	80	54	34.0	-



⁽¹⁾ Комплектуется гайкой ER16 MINI

HSK A-ER-M

Цанговый патрон ER MINI

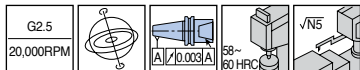
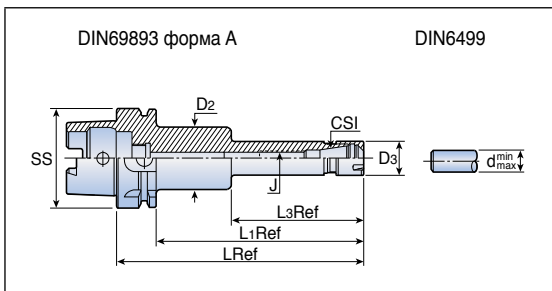

Обозначение	Размеры (мм)										
	SS	CSI	d _{мин.}	d _{макс.}	D ₂	D ₃	L	L ₁	L ₃	J	
HSK A 50	ER 16x100 M	50	ER16	0.5	10.0	-	22	100	74	-	M10
	ER 16x120 M	50	ER16	0.5	10.0	-	22	120	94	-	M10
	ER 20x100 M	50	ER20	1.0	13.0	-	28	100	74	-	M12
	ER 20x120 M	50	ER20	1.0	13.0	-	28	120	94	-	M12
HSK A 63	ER 16x100 M	63	ER16	0.5	10.0	-	22	100	74	-	M10
	ER 16x120 M	63	ER16	0.5	10.0	40	22	120	94	78	M10
	ER 16x160 M	63	ER16	0.5	10.0	40	22	160	134	85	M10
	ER 20x100 M	63	ER20	1.0	13.0	-	28	100	74	-	M12
	ER 20x120 M	63	ER20	1.0	13.0	-	28	120	94	-	M12
	ER 20x160 M	63	ER20	1.0	13.0	45	28	160	134	85	M12
	ER 16x100 M⁽¹⁾	100	ER16	0.5	10.0	-	22	100	71	-	M10
	ER 16x160 M⁽¹⁾	100	ER16	0.5	10.0	40	22	160	131	85	M10
HSK A 100	ER 20x100 M⁽¹⁾	100	ER20	1.0	13.0	-	28	100	71	-	M12
	ER 20x160 M⁽¹⁾	100	ER20	1.0	13.0	45	28	160	131	85	M12

• ⁽¹⁾ Балансировка G6,3 при 12000 об./мин.

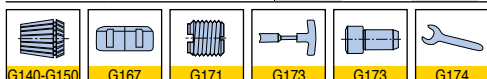

HSK FM-ER

Цанговый патрон ER

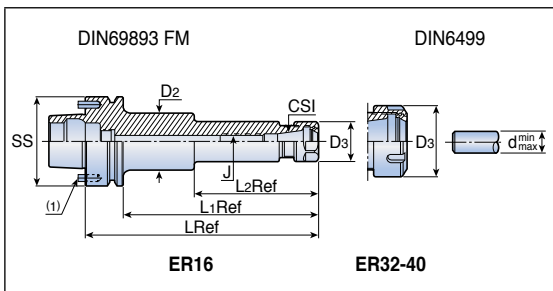
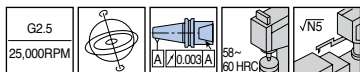

Обозначение	Размеры (мм)									
	SS	CSI	d _{мин.}	d _{макс.}	D ₂	D ₃	L	L ₁	L ₂	J
HSK FM 63 ER 16x80	63	ER16	0.5	10.0	-	28	80	54	-	M10
ER 16x100	63	ER16	0.5	10.0	-	28	100	74	-	M10
ER 16x120	63	ER16	0.5	10.0	-	28	120	94	-	M10
ER 16x160	63	ER16	0.5	10.0	40	28	160	134	85.6	M10
ER 32x80	63	ER32	2.0	20.0	-	50	80	54	-	-
ER 32x100	63	ER32	2.0	20.0	-	50	100	74	-	M22x1.5
ER 40x80	63	ER40	3.0	26.0	50	63	80	54	32.0	-
ER 40x100	63	ER40	3.0	26.0	50	63	100	74	32.0	M28x1.5

- ⁽¹⁾ При снятии направляющего штифта патрон можно использовать в качестве стандартного HSK F63

HSK A-ER-SHORT

Укороченный цанговый патрон ER

T-SHORT

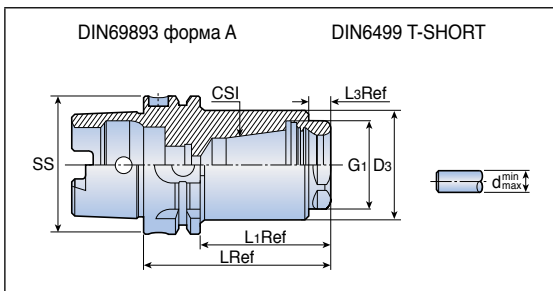
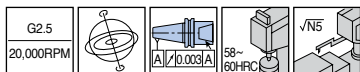

Обозначение	Размеры (мм)									
	SS	CSI	d _{мин.}	d _{макс.}	D ₃	L	L ₁	L ₃	G ₁	
HSK A 63 ER 32 SHORT	63	ER32	2.0	10.0	50	84.5	56.1	9.5	M40x1.5	
HSK A 100 ER 32 SHORT	100	ER32	2.0	10.0	50	89.5	60.5	9.5	M40x1.5	
ER 40 SHORT	100	ER40	3.0	26.0	70	104.5	75.5	9.5	M50x1.5	



- ⁽¹⁾ Комплектован гайкой ER16 MINI

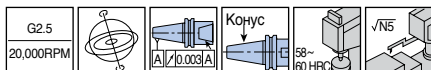
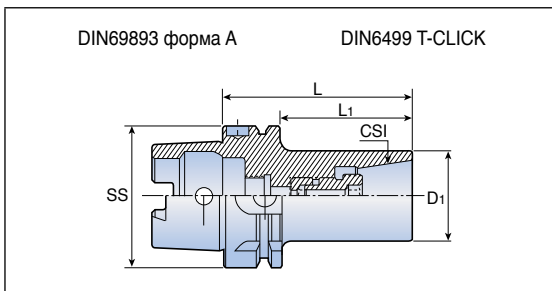

Обозначение	Размеры (мм)				
	SS	CSI	D1	L	L1
HSK A 63 ER32 CLICK-IN	63	SRF32	41	85	59

HSK A-TSK

Цанговый патрон TSK

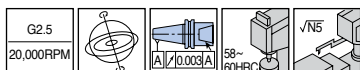
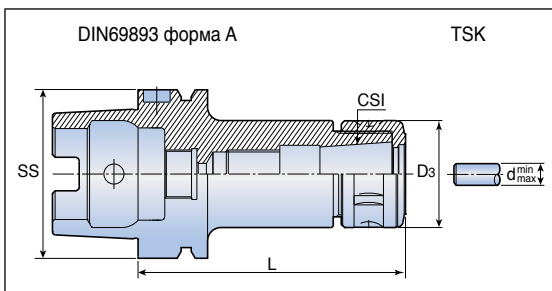

Обозначение	Размеры (мм)					
	SS	CSI	d _{мин.}	d _{макс.}	D3	L
HSK A 50						
TSK 6-80	50	TSK6	1.5	6.0	19.5	80
TSK 10-90	50	TSK10	1.5	10.0	27.5	90
TSK 16-100	50	TSK16	2.5	16.0	40.0	100
HSK A 63						
TSK 6-80	63	TSK6	1.5	6.0	19.5	80
TSK 10-90	63	TSK10	1.5	10.0	27.5	90
TSK 16-100	63	TSK16	2.5	16.0	40.0	100
TSK 25-120	63	TSK20	15.5	25.4	55.0	120
HSK A 100						
TSK 6-80	100	TSK6	1.5	6.0	19.5	80
TSK 10-90	100	TSK10	1.5	10.0	27.5	90
TSK 16-100	100	TSK16	2.5	16.0	40.0	100
TSK 25-120	100	TSK25	15.5	25.4	55.0	120



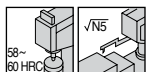
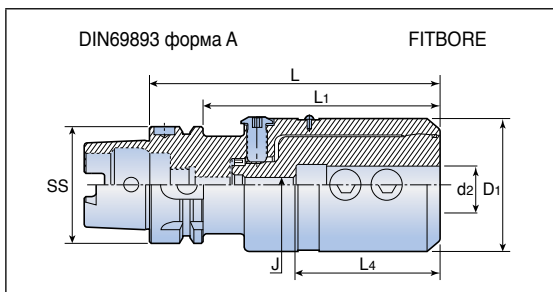

Обозначение	Размеры (мм)						
	SS	d2	D1	L	L1	L4	J
FITBORE HSK A 63 EM 25	63	25	72	142	116	71	M10
EM 32	63	32	72	142	116	71	M10
EM 40	63	40	72	142	116	71	M10

HSK A-TMC

Фрезерный патрон

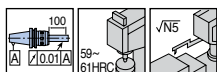
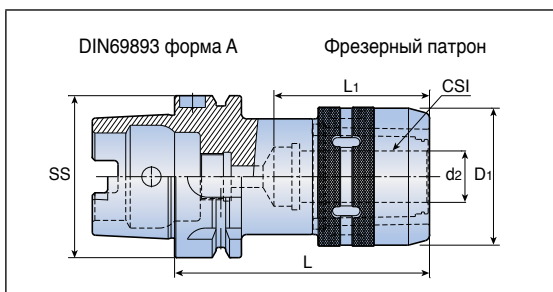

Обозначение	Размеры (мм)					
	SS	CSI	d2	D1	L	L1
HSK A 63 TMC 20-105	63	20	20	54.0	105	60
TMC 25-120	63	25	25	62.5	120	70
TMC 32-130	63	32	32	74.0	130	80
HSK A 100 TMC 20-110	100	20	20	54.0	110	60
TMC 25-130	100	25	25	62.5	130	70
TMC 32-135	100	32	32	74.0	135	80
TMC 42-135	100	42	42	92.0	135	90



HSK A-EM

Патрон для концевых фрез

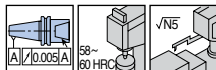
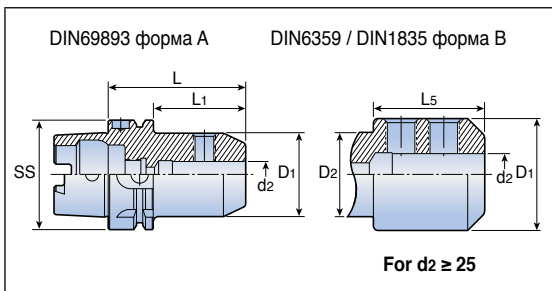

Обозначение	Размеры (мм)							
	SS	d2	D1	D2	L	L1	L5	
HSK A 50	EM 6x65	50	6	25	-	65	39	-
	EM 8x65	50	8	28	-	65	39	-
	EM 10x65	50	10	35	-	65	39	-
	EM 14x80	50	14	44	-	80	54	-
	EM 16x80	50	16	48	-	80	54	-
	EM 18x80	50	18	50	-	80	54	-
	EM 20x80	50	20	52	-	80	54	-
HSK A 63	EM 6x65	63	6	25	-	65	39	-
	EM 8x65	63	8	28	-	65	39	-
	EM 10x65	63	10	35	-	65	39	-
	EM 12x80	63	12	42	-	80	54	-
	EM 14x80	63	14	44	-	80	54	-
	EM 16x80	63	16	48	-	80	54	-
	EM 18x80	63	18	50	-	80	54	-
	EM 20x80	63	20	52	-	80	54	-
	EM 25x110	63	25	65	52	110	84	65.5
	EM 32x110	63	32	72	52	110	84	65.5
HSK A 100	EM 8x80	100	8	28	-	80	51	-
	EM 10x80	100	10	35	-	80	51	-
	EM 12x80	100	12	42	-	80	51	-
	EM 14x80	100	14	44	-	80	51	-
	EM 16x100	100	16	48	-	100	71	-
	EM 18x100	100	18	50	-	100	71	-
	EM 20x100	100	20	52	-	100	71	-
	EM 25x100	100	25	65	-	100	71	-
	EM 32x100	100	32	72	-	100	71	-
	EM 40x110	100	40	85	-	110	81	-



HSK A-EM-E

Патрон для концевых фрез - Whistle notch

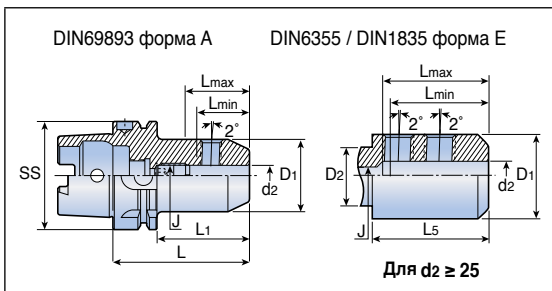
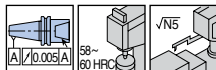

Обозначение	Размеры (мм)										
	SS	d2	D1	D2	L	L _{мин.}	L _{макс.}	L1	L5	J	
HSK A 50	EM 6x80 E	50	6	25	-	80	30	38	54	-	M5
	EM 8x80 E	50	8	28	-	80	35	40	54	-	M6
	EM 10x80 E	50	10	35	-	80	39	44	54	-	M8
	EM 12x90 E	50	12	42	-	90	44	49	64	-	M10
	EM 14x90 E	50	14	44	-	90	44	49	64	-	M10
	EM 16x90 E	50	16	48	-	90	47	52	64	-	M12
	EM 18x90 E	50	18	50	-	90	47	52	64	-	M12
	EM 20x100 E	50	20	52	-	100	49	54	74	-	M16
HSK A 63	EM 6x80 E	63	6	25	-	80	32	40	54	-	M5
	EM 8x80 E	63	8	28	-	80	35	40	54	-	M6
	EM 10x80 E	63	10	35	-	80	39	44	54	-	M8
	EM 12x90 E	63	12	42	-	90	44	49	64	-	M10
	EM 14x90 E	63	14	44	-	90	44	49	64	-	M10
	EM 16x100 E	63	16	48	-	100	47	52	74	-	M12
	EM 18x100 E	63	18	50	-	100	47	55	74	-	M12
	EM 20x100 E	63	20	52	-	100	49	54	74	-	M16
	EM 25x110 E	63	25	65	52	110	54	61	84	65.5	M16
EM 32x110 E	63	32	72	52	110	58	63	84	65.5	M20x1.5	
HSK A 100	EM 6x90 E	100	6	25	-	90	35	40	61	-	M5
	EM 8x90 E	100	8	28	-	90	35	40	61	-	M6
	EM 10x90 E	100	10	35	-	90	39	44	61	-	M8
	EM 12x100 E	100	12	42	-	100	44	54	71	-	M10
	EM 14x100 E	100	14	44	-	100	44	54	71	-	M10
	EM 16x100 E	100	16	48	-	100	47	52	71	-	M12
	EM 18x100 E	100	18	50	-	100	47	52	71	-	M12
	EM 20x110 E	100	20	52	-	110	49	54	81	-	M16
	EM 25x120 E	100	25	65	-	120	54	61	91	-	M20x1.5
	EM 32x120 E	100	32	72	-	120	58	63	91	-	M20x1.5

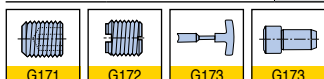

Термо патрон для твердосплавных и стальных хвостовиков

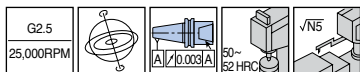
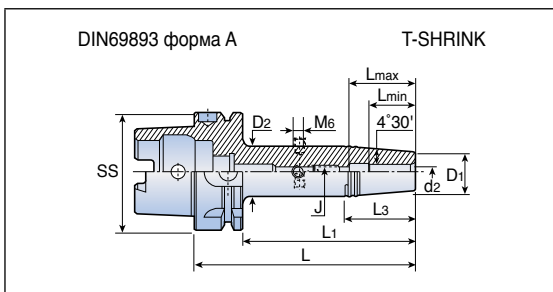

Обозначение	Размеры (мм)										
	SS	d2	D1	D2	L	L _{мин.}	L _{макс.}	L1	L3	J	Шестигранник
HSK A 50 SRKIN 6x80	50	6	21	27	80	25	36	54	38	M5	2.5
SRKIN 8x80	50	8	21	27	80	25	36	54	38	M6	3.0
SRKIN 10x85	50	10	24	32	85	31	42	59	51	M8	4.0
SRKIN 12x90	50	12	24	32	90	36	47	64	51	M10	5.0
SRKIN 14x90	50	14	27	34	90	36	47	64	45	M10	5.0
SRKIN 16x95	50	16	27	34	95	39	50	69	45	M10	5.0
HSK A 63 SRKIN 6x80	63	6	21	27	80	25	36	54	38	M5	2.5
SRKIN 6x120	63	6	21	27	120	25	36	94	38	M5	2.5
SRKIN 6x160	63	6	21	27	160	25	36	134	38	M5	2.5
SRKIN 8x80	63	8	21	27	80	25	36	54	38	M6	3.0
SRKIN 8x120	63	8	21	27	120	25	36	94	38	M6	3.0
SRKIN 8x160	63	8	21	27	160	25	36	134	38	M6	3.0
SRKIN 10x85	63	10	24	32	85	31	42	54	51	M8	4.0
SRKIN 10x120	63	10	24	32	120	31	42	94	51	M8	4.0
SRKIN 10x160	63	10	24	32	160	31	42	134	51	M8	4.0
SRKIN 12x90	63	12	24	32	90	36	42	64	51	M8	4.0
SRKIN 12x120	63	12	24	32	120	36	47	94	51	M10	5.0
SRKIN 12x160	63	12	24	32	160	36	47	134	51	M10	5.0
SRKIN 14x90	63	14	27	34	90	36	47	64	45	M10	5.0
SRKIN 14x120	63	14	27	34	120	36	47	94	45	M10	5.0
SRKIN 14x160	63	14	27	34	160	36	47	134	45	M10	5.0
SRKIN 16x75	63	16	27	34	75	39	50	49	-	-	-
SRKIN 16x95	63	16	27	34	95	39	50	69	44	M12	6.0
SRKIN 16x120	63	16	27	34	120	39	50	94	44	M12	6.0
SRKIN 16x160	63	16	27	34	160	39	50	134	44	M12	6.0
SRKIN 18x95	63	18	33	42	95	39	50	69	57	M12	6.0
SRKIN 18x120	63	18	33	42	120	39	50	94	57	M12	6.0
SRKIN 18x160	63	18	33	42	160	39	50	134	57	M12	6.0
SRKIN 20x75	63	20	33	41	75	41	50	49	-	-	-
SRKIN 20x100	63	20	33	42	100	41	52	74	57	M16	8.0
SRKIN 20x120	63	20	33	42	120	41	52	94	57	M16	8.0
SRKIN 20x160	63	20	33	42	160	41	52	134	57	M16	8.0
SRKIN 25x85	63	25	44	53	85	47	58	59	-	-	-

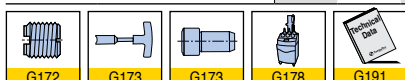

• Патроны серии T-Shrink использовать только вместе с устройством индукционного нагрева

Термо патрон для твердосплавных и стальных хвостовиков

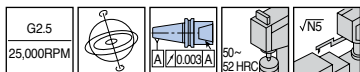
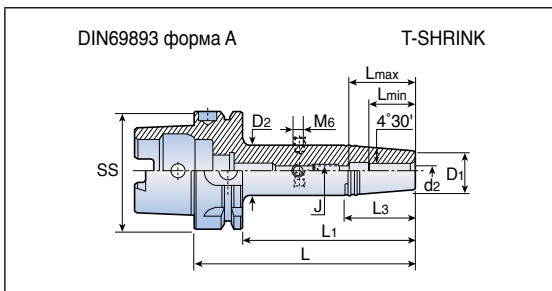

Обозначение	Размеры (мм)											
	SS	d2	D1	D2	L	L _{мин.}	L _{макс.}	L ₁	L ₃	J	Шестигранник	
HSK A 63	SRKIN 25x115	63	25	44	53	115	47	58	89	55	M16	8.0
	SRKIN 32x85	63	32	44	53	85	47	58	59	-	-	-
	SRKIN 32x120	63	32	44	53	120	47	58	94	55	M16	8.0
HSK A 100	SRKIN 6x85	100	6	21	27	85	25	36	56	38	M5	2.5
	SRKIN 6x120	100	6	21	27	120	25	36	91	38	M5	2.5
	SRKIN 6x160	100	6	21	27	160	25	36	131	38	M6	3.0
	SRKIN 8x85	100	8	21	27	85	25	36	56	38	M6	3.0
	SRKIN 8x120	100	8	21	27	120	25	36	91	38	M6	3.0
	SRKIN 8x160	100	8	21	27	160	25	36	131	38	M6	3.0
	SRKIN 10x90	100	10	24	32	90	31	42	61	51	M8	4.0
	SRKIN 10x120	100	10	24	32	120	31	42	91	51	M8	4.0
	SRKIN 10x160	100	10	24	32	160	31	42	131	51	M8	4.0
	SRKIN 12x95	100	12	24	32	95	36	47	66	51	M10	5.0
	SRKIN 12x120	100	12	24	32	120	36	47	91	51	M10	5.0
	SRKIN 12x160	100	12	24	32	160	36	47	131	51	M10	5.0
	SRKIN 14x95	100	14	27	34	95	36	47	66	45	M10	5.0
	SRKIN 14x120	100	14	27	34	120	36	47	91	45	M10	5.0
	SRKIN 14x160	100	14	27	34	160	36	47	131	45	M10	5.0
	SRKIN 16x100	100	16	27	34	100	39	50	71	45	M12	6.0
	SRKIN 16x120	100	16	27	34	120	39	50	91	45	M12	6.0
	SRKIN 16x160	100	16	27	34	160	39	50	131	45	M12	6.0
SRKIN 18x100	100	18	33	42	100	39	50	71	57	M12	6.0	
SRKIN 18x160	100	18	33	42	160	39	50	131	57	M12	6.0	
SRKIN 20x105	100	20	33	42	105	41	52	76	57	M16	8.0	
SRKIN 20x160	100	20	33	42	160	41	52	131	57	M16	8.0	
SRKIN 25x115	100	25	44	53	115	47	58	86	57	M16	8.0	
SRKIN 32x120	100	32	44	53	120	47	58	91	57	M16	8.0	

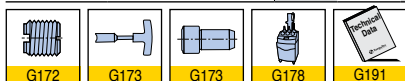

• Патроны серии T-SHRINK использовать только вместе с устройством индукционного нагрева

Термо патрон для твердсплавных и стальных хвостовиков

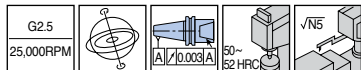
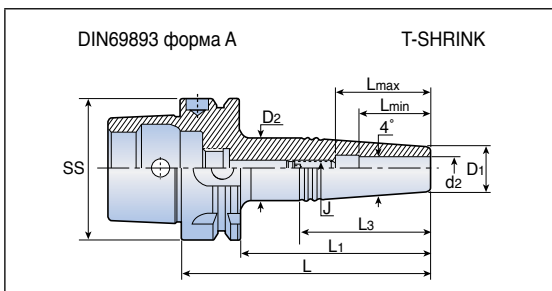

Обозначение	Размеры (мм)										
	SS	d2	D1	D2	L	L _{мин.}	L _{макс.}	L1	L3	J	Шестигранник
HSK A 63 SRK 3x50	63	3	10	17	76	10	16	50	-	M6	3.0
SRK 3x85	63	3	10	21	111	10	16	85	79	M6	3.0
SRK 4x50	63	4	10	17	76	12	18	50	-	M6	3.0
SRK 4x85	63	4	10	21	111	12	18	85	79	M6	3.0
SRK 5x50	63	5	10	17	76	15	21	50	-	M6	3.0
SRK 5x85	63	5	10	21	111	15	21	85	79	M6	3.0
SRK 6x50	63	6	11	18	76	18	24	50	-	M8	4.0
SRK 6x85	63	6	11	22	111	18	24	85	79	M8	4.0
SRK 8x50	63	8	14	20	76	25	36	50	43	M6	3.0
SRK 8x85	63	8	14	23	111	25	36	85	64	M6	3.0
SRK 10x50	63	10	16	23	76	30	41	50	-	M8	4.0
SRK 10x85	63	10	16	26	111	30	41	85	72	M8	4.0
SRK 12x50	63	12	20	27	76	32	43	50	-	M8	4.0
SRK 12x85	63	12	20	30	111	32	43	85	72	M8	4.0



Термо патрон для твердосплавных и стальных хвостовиков

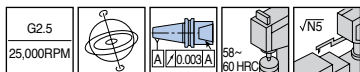
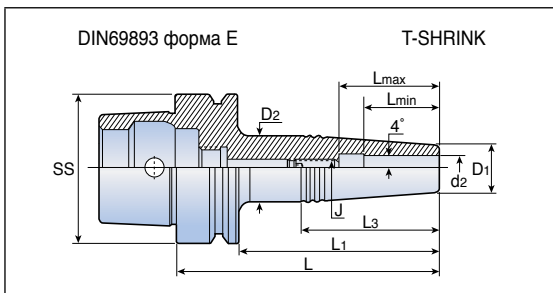

Обозначение	Размеры (мм)										
	SS	d2	D1	D2	L	L _{мин.}	L _{макс.}	L1	L3	J	Шестигранник
HSK E 32 SRK 3x45	32	3	10	13	65	10	16	45	30.0	M4	2.0
SRK 4x45	32	4	10	15	65	12	18	45	35.0	M4	2.0
SRK 5x45	32	5	10	15	65	15	25	45	35.0	M4	2.0
SRK 6x45	32	6	11	16	65	18	28	45	35.0	M4	2.0
SRK 8x45	32	8	14	20	65	25	35	45	42.0	M4	2.0
SRK 10x45	32	12	16	22	65	30	40	45	42.0	M4	2.0
SRK 12x45	32	12	20	25	65	32	40	45	35.6	M4	2.0
HSK E 40 SRK 3x45	40	3	10	13	65	10	16	45	30.0	M5	2.5
SRK 3x80	40	3	10	19	100	10	16	80	64.0	M5	2.5
SRK 4x45	40	4	10	15	65	12	18	45	35.0	M5	2.5
SRK 4x80	40	4	10	19	100	12	18	80	64.0	M5	2.5
SRK 5x45	40	5	10	15	65	15	25	45	35.0	M4	2.0
SRK 5x80	40	5	10	19	100	15	25	80	64.0	M4	2.0
SRK 6x45	40	6	11	16	65	18	28	45	35.0	M5	2.5
SRK 6x80	40	6	11	20	100	18	28	80	64.0	M5	2.5
SRK 8x45	40	8	14	20	65	25	35	45	42.0	M5	2.5
SRK 8x80	40	8	14	23	100	25	35	80	64.0	M6	3.0
SRK 10x45	40	10	16	22	65	30	40	45	42.0	M5	2.5
SRK 10x80	40	10	16	24	100	30	40	80	60.0	M8	4.0
SRK 12x45	40	12	20	26	65	32	42	45	42.0	M5	2.5
SRK 12x80	40	12	20	28	100	32	42	80	56.0	M10	5.0
HSK E 50 SRK 3x45	50	3	10	15	71	10	16	45	36.0	M5	2.5
SRK 3x80	50	3	10	19	106	10	16	80	64.0	M5	2.5
SRK 4x45	50	4	10	15	71	12	18	45	36.0	M5	2.5
SRK 4x80	50	4	10	19	106	12	18	80	64.0	M5	2.5
SRK 5x45	50	5	10	15	71	15	21	45	36.0	M6	3.0
SRK 5x80	50	5	10	15	106	15	21	80	64.0	M6	3.0
SRK 6x45	50	6	11	16	71	18	28	45	36.0	M5	2.5
SRK 6x80	50	6	11	20	106	18	28	80	64.0	M5	2.5
SRK 8x45	50	8	14	20	71	25	35	45	43.0	M6	3.0
SRK 8x80	50	8	14	23	106	25	35	80	64.0	M6	3.0
SRK 10x45	50	10	16	22	71	30	37	45	42.0	M6	3.0
SRK 10x80	50	10	16	24	106	30	40	80	60.0	M8	4.0
SRK 12x45	50	12	20	26	71	32	39	45	42.0	M6	3.0
SRK 12x80	50	12	20	28	106	32	42	80	57.0	M10	5.0



Термо патрон для твердосплавных и стальных хвостовиков

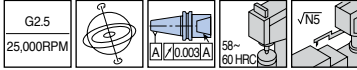
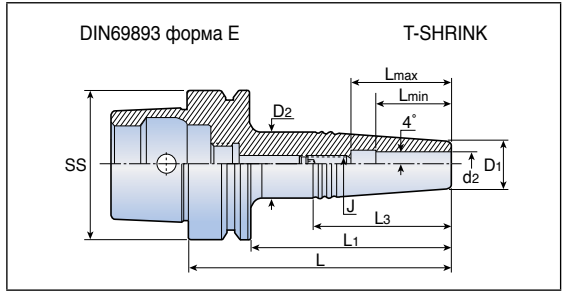

Обозначение	Размеры (мм)										
	SS	d2	D1	D2	L	L _{мин.}	L _{макс.}	L1	L3	J	Шестигранник
HSK E 63 SRK 3x50	63	3	10	17	76	10	16	50	48	M6	3.0
SRK 3x80	63	3	10	19	106	10	16	80	64	M6	3.0
SRK 4x50	63	4	10	17	76	12	18	50	48	M6	3.0
SRK 4x80	63	4	10	19	106	12	18	80	64	M6	3.0
SRK 5x50	63	5	10	15	71	15	21	50	47	M6	3.0
SRK 5x80	63	5	10	19	106	15	21	80	64	M6	3.0
SRK 6x50	63	6	11	18	76	18	24	50	48	M8	4.0
SRK 6x80	63	6	11	20	106	18	24	80	64	M8	4.0
SRK 8x50	63	8	14	21	76	25	35	50	48	M6	3.0
SRK 8x80	63	8	14	23	106	25	35	80	64	M6	3.0
SRK 10x50	63	10	16	23	76	30	40	50	48	M8	4.0
SRK 10x80	63	10	16	24	106	30	40	80	60	M8	4.0
SRK 12x50	63	12	20	27	76	32	42	50	48	M8	4.0
SRK 12x80	63	12	20	28	106	32	42	80	57	M10	5.0
SRK 12x90	63	12	20	28	116	32	43	90	57	M8	4.0



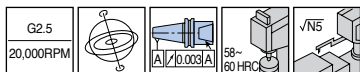
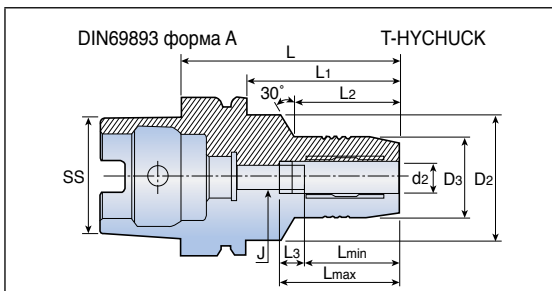

Обозначение	Размеры (мм)											
	SS	d2	D2	D3	L	L _{мин.}	L _{макс.}	L1	L2	L3	J	
HSK A 40	THC 6-70	40	6	34	28	70	27.5	37.5	50	28	10	M5
	THC 8-70	40	8	34	30	70	27.5	37.5	50	28	10	M6
	THC 10-75	40	10	34	32	75	32.5	42.5	55	34	10	M6
	THC 12-85	40	12	34	34	85	37.5	47.5	60	60	10	M6
HSK A 50	THC 6-70	50	6	40	28	70	27.5	37.5	44	28	10	M5
	THC 8-70	50	8	40	30	70	27.5	37.5	44	28	10	M6
	THC 10-75	50	10	40	32	75	32.5	42.5	49	34	10	M8x1
	THC 12-80	50	12	40	34	85	37.5	47.5	59	39	10	M10x1
	THC 16-90	50	16	53	38	90	42.5	52.5	64	30	10	M10x1
	THC 20-90	50	20	60	43	90	42.5	52.5	64	29	10	M10x1
	THC 25-120	50	25	63	57	120	51.0	61.0	94	59	10	M16x1
HSK A 63	THC 6-70	63	6	50	28	70	27.5	37.5	44	24	10	M5
	THC 8-70	63	8	50	30	70	27.5	37.5	44	24	10	M6
	THC 10-80	63	10	50	32	80	32.5	42.5	54	35	10	M8x1
	THC 12-85	63	12	50	34	85	37.5	47.5	59	40	10	M10x1
	THC 14-85	63	14	50	36	85	37.5	47.5	59	40	10	M10x1
	THC 16-90	63	16	50	38	90	42.5	52.5	64	46	10	M10x1
	THC 20-90	63	20	50	43	90	42.5	52.5	64	48	10	M10x1
	THC 25-120	63	25	63	57	120	51.0	61.0	94	59	10	M16x1
	THC 32-125	63	32	75	63	125	55.0	65.0	99	63	10	M16x1
	HSK A 100	THC 6-80⁽¹⁾	100	6	50	28	80	27.5	37.5	46	29	10
THC 8-75⁽¹⁾		100	8	54	30	75	27.5	37.5	46	26	10	M6
THC 10-90⁽¹⁾		100	10	50	32	90	32.5	42.5	61	42	10	M8x1
THC 12-95⁽¹⁾		100	12	50	34	95	37.5	47.5	66	47	10	M10x1
THC 16-100⁽¹⁾		100	16	50	38	100	42.5	52.5	71	53	10	M10x1
THC 18-100⁽¹⁾		100	18	50	41	100	42.5	52.5	71	53	10	M10x1
THC 20-105⁽¹⁾		100	20	50	43	105	42.5	52.5	76	59	10	M10x1
THC 25-110⁽¹⁾		100	25	63	57	110	51.0	61.0	81	62	10	M16x1
THC 32-110⁽¹⁾	100	32	75	63	110	55.0	65.0	81	62	10	M16x1	

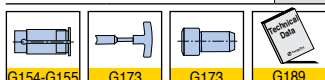

• ⁽¹⁾ Балансировка до G6,3 при 12000 об./мин.

HSK E-THC



Гидравлический патрон

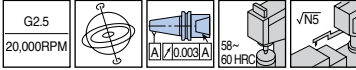
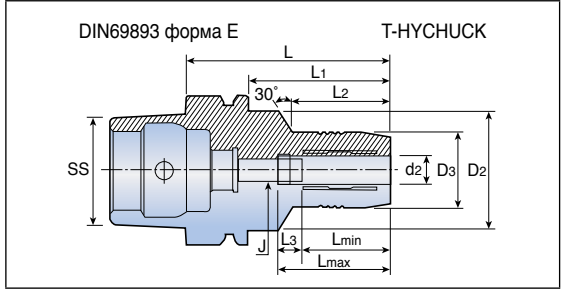

Обозначение	Размеры (мм)										
	SS	d2	D2	D3	L	L _{мин.}	L _{макс.}	L1	L2	L3	J
HSK E 40											
THC 6-70	40	6	34	28	70	27.5	37.5	50	28	10	M5
THC 8-70	40	8	34	30	70	27.5	37.5	50	28	10	M6
THC 10-75	40	10	34	32	75	32.5	42.5	55	34	10	M6
THC 12-80	40	12	34	34	80	37.5	47.5	60	-	10	M6
HSK E 50											
THC 6-70	50	6	40	28	70	27.5	37.5	44	28	10	M5
THC 8-70	50	8	40	30	70	27.5	37.5	44	28	10	M6
THC 10-75	50	10	40	32	75	32.5	42.5	49	34	10	M8x1
THC 12-85	50	12	40	34	85	37.5	47.5	59	44	10	M10x1
THC 16-90	50	16	53	38	90	42.5	52.5	64	30	10	M10x1
THC 20-90	50	20	60	43	90	42.5	52.5	64	29	10	M10x1

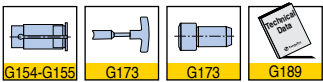

HSK A-SEM

Оправка для торцевых/насадных фрез

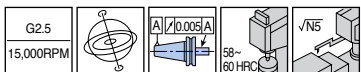
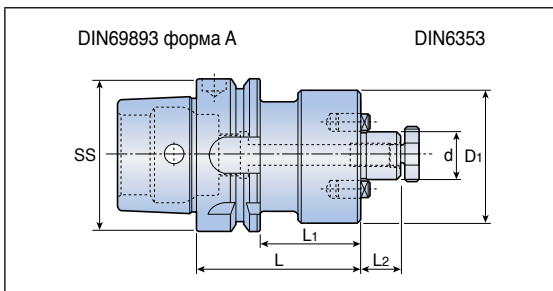

Обозначение	Размеры (мм)					
	SS	d	D1	L	L1	L2
HSK A 40 SEM 22	40	22	47	50	30	19
SEM 27	40	27	58	55	35	21
HSK A 50 SEM 16x50	50	16	38	50	24	17
SEM 22x60	50	22	47	60	34	19
SEM 27x60	50	27	58	60	34	21
HSK A 63 SEM 16x50	63	16	38	50	24	17
SEM 22x50	63	22	47	50	24	19
SEM 27x60	63	27	58	60	34	21
SEM 32x60	63	32	66	60	34	24
SEM 40x60	63	40	82	60	24	27
HSK A 100 SEM 22x50⁽¹⁾	100	22	47	50	21	19
SEM 27x50⁽¹⁾	100	27	58	50	21	21
SEM 32x50⁽¹⁾	100	32	66	50	21	24
SEM 40x60⁽¹⁾	100	40	82	60	31	27
SEM 50x70⁽¹⁾	100	50	95	70	41	30

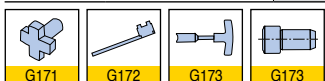

- Ключ не входит в поставку
- ⁽¹⁾ Балансировка G6,3 при 12000 об./мин.

HSK A-SEM-C

Оправка для торцевых/насадных фрез с внутренней подачей СОЖ

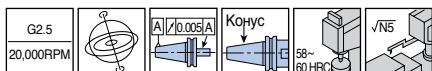
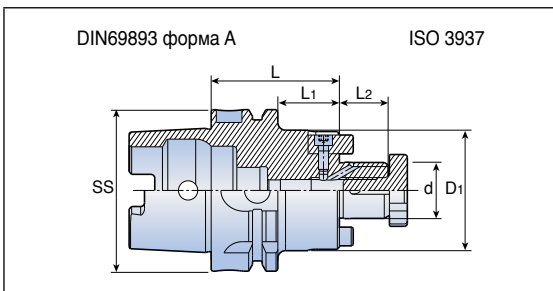

Обозначение	Размеры (мм)						
	SS	d	D1	L	L1	L2	
HSK A 63	SEM 16x50 C	63	16	38	50	24	17
	SEM 16x100 C	63	16	38	100	74	17
	SEM 22x50 C	63	22	47	50	24	19
	SEM 22x100 C	63	22	47	100	74	19
	SEM 27x60 C	63	27	58	60	34	21
	SEM 27x100 C	63	27	58	100	74	21
	SEM 32x60 C	63	32	66	60	34	24
	SEM 32x100 C	63	32	66	100	74	24
HSK A 100	SEM 16x50 C⁽¹⁾	100	16	38	50	21	17
	SEM 16x100 C⁽¹⁾	100	16	38	100	71	17
	SEM 22x50 C⁽¹⁾	100	22	47	50	21	19
	SEM 22x100 C⁽¹⁾	100	22	47	100	71	19
	SEM 27x50 C⁽¹⁾	100	27	58	50	21	21
	SEM 27x100 C⁽¹⁾	100	27	58	100	71	21
	SEM 32x50 C⁽¹⁾	100	32	66	50	21	24
	SEM 32x100 C⁽¹⁾	100	32	66	100	71	24

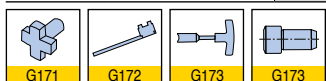

• ⁽¹⁾ Балансировка до G6,3 при 12000 об./мин.

HSK A FM

Оправка для торцевых фрез

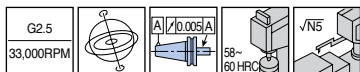
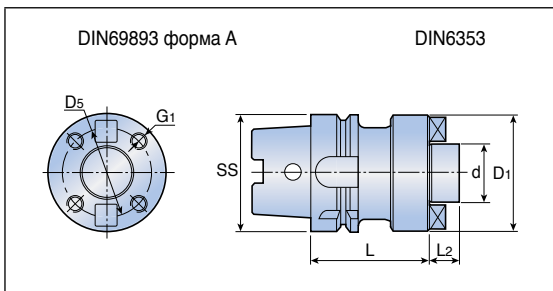

Обозначение	Размеры (мм)						
	SS	d	D1	D5	L	L2	G1
HSK A 100 FM 60x70	100	60	128	101.6	70	40	M16

• Ключ не входит в поставку

HSK FM-SEM

Оправка для торцевых фрез

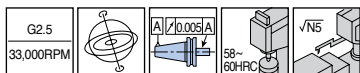
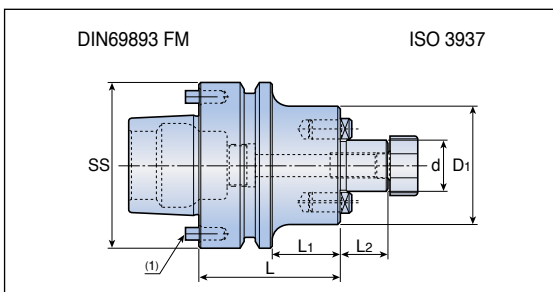

Обозначение	Размеры (мм)					
	SS	d	D1	L	L1	L2
HSK FM 63 SEM 22x60	63	22	47	60	34	19
SEM 27x60	63	27	58	60	34	21
SEM 32x60	63	32	66	60	34	24

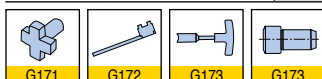

• ⁽¹⁾ При снятии направляющего штифта патрона можно использовать в качестве стандартного HSK F63

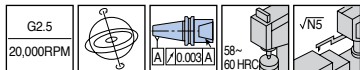
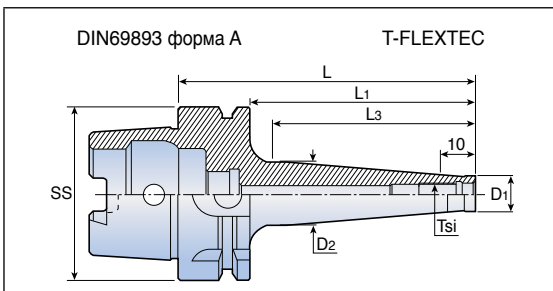

Обозначение	Размеры (мм)						
	SS	Tsi	D1	D2	L	L1	L3
HSK A 63							
ODP 6x59	63	M6	9.8	11.5	59	33	25
ODP 6x109	63	M6	9.8	23.0	109	83	75
ODP 8x59	63	M8	13.1	15.0	59	33	25
ODP 8x109	63	M8	13.1	23.0	109	83	75
ODP 10x59	63	M10	18.0	20.0	59	33	25
ODP 10x109	63	M10	18.0	28.0	109	83	75
ODP 12x59	63	M12	21.0	24.0	59	33	25
ODP 12x109	63	M12	21.0	31.0	109	83	75
ODP 16x59	63	M16	29.0	34.0	59	33	25
ODP 16x109	63	M16	29.0	34.0	109	83	75
HSK A 100							
ODP 12x87⁽¹⁾	100	M12	23.0	30.0	87	58	50
ODP 12x137⁽¹⁾	100	M12	23.0	30.0	137	108	100
ODP 12x187⁽¹⁾	100	M12	23.0	40.0	187	158	150
ODP 12x237⁽¹⁾	100	M12	23.0	46.0	237	208	200
ODP 16x87⁽¹⁾	100	M16	29.0	31.5	87	58	50
ODP 16x137⁽¹⁾	100	M16	29.0	41.5	137	108	100
ODP 16x187⁽¹⁾	100	M16	29.0	55.0	187	158	150
ODP 16x237⁽¹⁾	100	M16	29.0	55.0	237	208	200

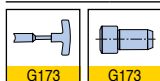

• ⁽¹⁾ Балансировка G6,3 при 12000 об./мин.

BT MAS



BT MAS 403 Форма A/AD/B/ADB

Стандартный патрон

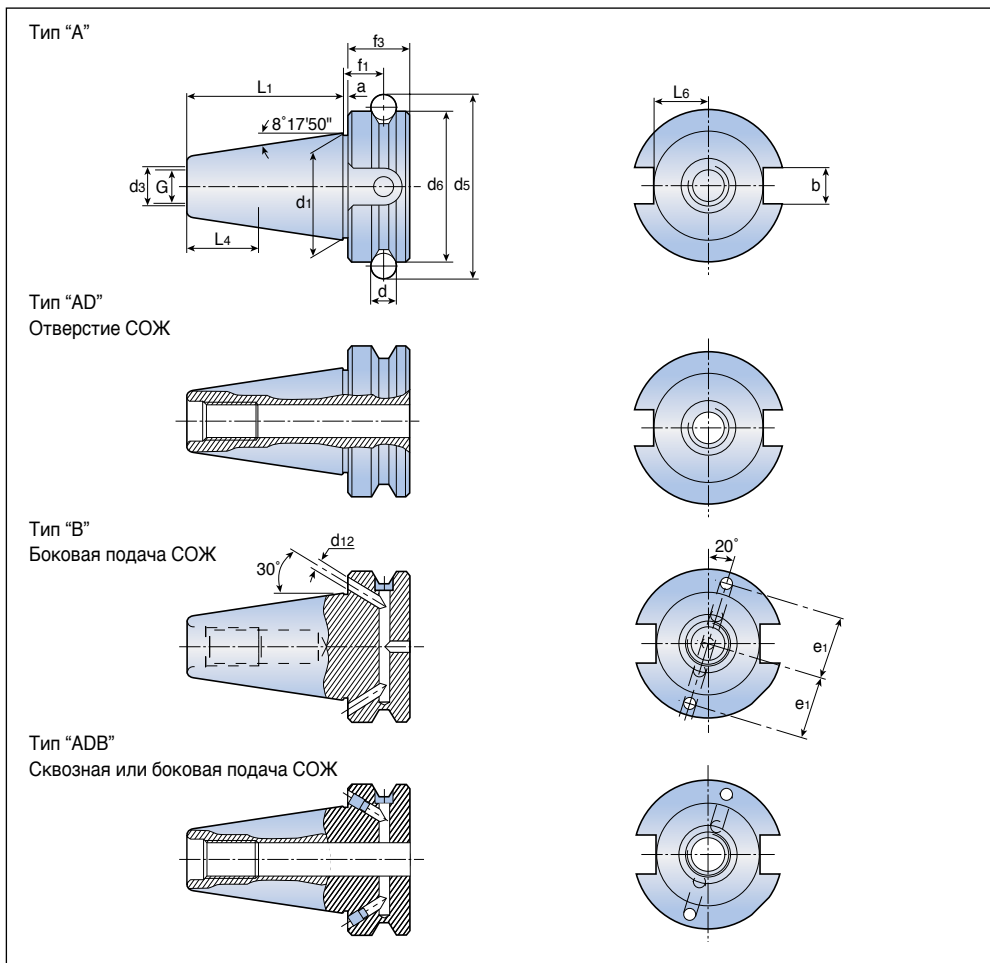

Конус	a ±0.1	b (H12)	d	d1	G	d3 (H8)	d5	d6 (H8)
30	2	16.1	8	31.75	M12	12.5	56.144	46
40	2	16.1	10	44.45	M16	17.0	75.679	63
50	3	25.7	15	69.85	M24	25.0	119.020	100

Конус	f1 ±0.1	f3	L1 ±0.2	L4 _{мин.}	L6 -0.2	e1 ±0.1	d12	Конус AT3
30	13.6	20	48.4	24	16.3	21	4	0.002
40	16.6	25	65.4	30	22.6	27	4	0.003
50	23.2	35	101.8	45	35.4	42	6	0.004

* для нескладской позиции: Поставляется в случае наличия.

Если нет на складе, применяется МОК (Минимальное количество заказа).



BT MAS-403 форма AD DIN6499 T-BALANCE

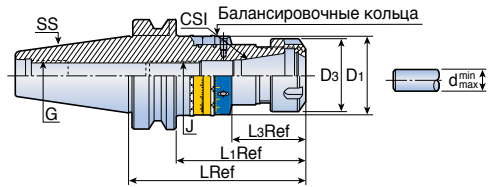

G2.5 ⁽¹⁾			Конус		
20.000RPM		A/0.003A			

Обозначение	Размеры (мм)										
	SS	CSI	d _{мин.}	d _{макс.}	D1	D3	L	L1	L3	G	J
BT40 ER 16x100 BIN	40	ER16	0.5	10.0	44	28	100	73	44.0	M16	M10
ER 16x150 BIN	40	ER16	0.5	10.0	44	28	150	123	78.7	M16	M10
ER 20x100 BIN	40	ER20	1.0	13.0	44	34	100	73	44.6	M16	M12
ER 20x150 BIN	40	ER20	1.0	13.0	44	34	150	123	79.6	M16	M12
ER 25x100 BIN	40	ER25	1.0	16.0	44	42	100	73	43.0	M16	M16
ER 25x150 BIN	40	ER25	1.0	16.0	44	42	150	123	79.0	M16	M16
ER 32x100 BIN	40	ER32	2.0	20.0	60	50	100	73	44.0	M16	M22x1.5
ER 32x150 BIN	40	ER32	2.0	20.0	60	50	150	123	94.0	M16	M22x1.5
ER 40x100 BIN	40	ER40	3.0	26.0	60	63	100	73	44.0	M16	M28x1.5

G140-G150	G167	G168-G170	G171	G174	G188
-----------	------	-----------	------	------	------

•⁽¹⁾ Значение балансировки

BT-ER

Цанговый патрон ER

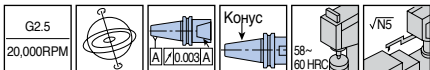
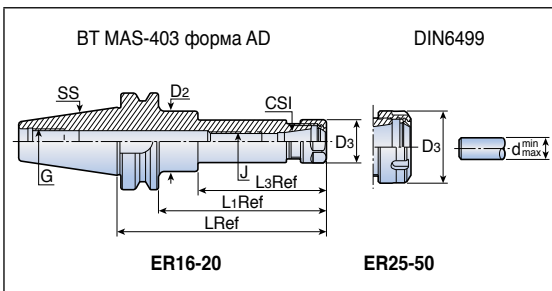

Обозначение	Размеры (мм)										
	SS	CSI	d _{мин.}	d _{макс.}	D ₂	D ₃	L	L ₁	L ₃	G	J
BT30 ER 16x70 ⁽¹⁾	30	ER16	0.5	10.0	-	28	70	48	-	M12	M10
ER 16x100 ⁽¹⁾	30	ER16	0.5	10.0	-	28	100	73	-	M12	M10
ER 20x70 ⁽¹⁾	30	ER20	1.0	13.0	-	34	70	48	-	M12	M12
ER 25x60 ⁽¹⁾	30	ER25	1.0	16.0	-	42	60	38	-	M12	M16
ER 32x60 ⁽¹⁾	30	ER32	2.0	20.0	-	50	60	38	-	M12	M18x1.5
BT40 ER 16x70	40	ER16	0.5	10.0	-	28	70	43	-	M16	M12
ER 16x100	40	ER16	0.5	10.0	-	28	100	73	-	M16	M12
ER 16x150 ⁽¹⁾	40	ER16	0.5	10.0	40	28	150	123	85	M16	M12
ER 16x200 ⁽¹⁾	40	ER16	0.5	10.0	40	28	200	173	85	M16	M10
ER 20x70	40	ER20	1.0	13.0	-	34	70	43	-	M16	M12
ER 20x100	40	ER20	1.0	13.0	-	34	100	73	-	M16	M12
ER 20x120	40	ER20	1.0	13.0	-	34	120	93	-	M16	M12
ER 20x150 ⁽¹⁾	40	ER20	1.0	13.0	-	34	150	123	-	M16	M12
ER 25x60	40	ER25	1.0	13.0	-	42	60	33	-	M16	M16
ER 25x100	40	ER25	1.0	16.0	-	42	100	73	-	M16	M16
ER 25x150 ⁽¹⁾	40	ER25	1.0	16.0	-	42	150	123	-	M16	M16
ER 32x60	40	ER32	2.0	20.0	-	50	60	33	-	M16	M22x1.5
ER 32x100	40	ER32	2.0	20.0	-	50	100	73	-	M16	M22x1.5
ER 32x150 ⁽¹⁾	40	ER32	2.0	20.0	-	50	150	123	-	M16	M22x1.5
ER 32x200 ⁽¹⁾	40	ER32	2.0	20.0	-	50	200	162	-	M17	M22x1.6
ER 40x80	40	ER40	3.0	26.0	-	63	80	53	-	M16	M28x1.5
ER 40x100	40	ER40	3.0	26.0	-	63	100	73	-	M16	M28x1.5
ER 40x150 ⁽¹⁾	40	ER40	3.0	26.0	-	63	150	123	-	M16	M28x1.5
ER 50x90	40	ER50	10.0	34.0	-	78	90	63	-	M16	M28x1.5
BT50 ER 16x100 ⁽¹⁾	50	ER16	0.5	10.0	-	28	100	62	-	M24	M12
ER 16x125 ⁽¹⁾	50	ER16	0.5	10.0	-	28	125	87	-	M24	M12
ER 16x150 ⁽¹⁾	50	ER16	0.5	10.0	-	28	150	112	-	M24	M12
ER 16x200 ⁽¹⁾	50	ER16	0.5	10.0	40	28	200	162	85	M24	M10
ER 20x100 ⁽¹⁾	50	ER20	1.0	10.0	-	34	100	62	-	M24	M12
ER 20x125 ⁽¹⁾	50	ER20	1.0	13.0	-	34	125	87	-	M24	M12
ER 20x150 ⁽¹⁾	50	ER20	1.0	13.0	-	34	150	112	-	M24	M12
ER 20x200 ⁽¹⁾	50	ER20	1.0	13.0	50	34	200	162	85	M24	M12

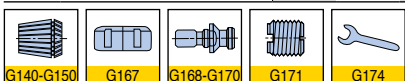

- Патроны с подводом СОЖ через фланец, имеют дополнительное буквенное обозначение - В
- ⁽¹⁾ Балансировка G6,3 при 12000 об./мин.

BT-ER

Цанговый патрон ER

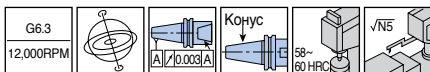
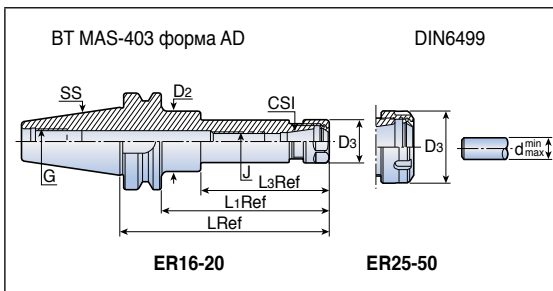

Обозначение	Размеры (мм)											
	SS	CSI	д _{мин.}	д _{макс.}	D ₂	D ₃	L	L ₁	L ₃	G	J	
BT50 ER 25x100	50	ER25	1.0	16.0	-	42	100	62	-	M24	M16	
ER 25x150	50	ER25	1.0	16.0	-	42	150	112	-	M24	M16	
ER 25x200	50	ER25	1.0	16.0	55	42	200	162	87	M24	M16	
ER 32x100	50	ER32	2.0	20.0	-	50	100	62	-	M24	M22x1.5	
ER 32x125	50	ER32	2.0	20.0	-	50	125	87	-	M24	M22x1.5	
ER 32x150	50	ER32	2.0	20.0	-	50	150	112	-	M24	M22x1.5	
ER 32x200	50	ER32	2.0	20.0	63	50	200	162	88	M24	M22x1.5	
ER 40x100	50	ER40	3.0	26.0	-	63	100	62	-	M24	M28x1.5	
ER 40x150	50	ER40	3.0	26.0	-	63	150	112	-	M24	M28x1.5	
ER 40x200	50	ER40	3.0	26.0	-	63	200	162	-	M24	M28x1.5	
ER 50x100	50	ER50	3.0	26.0	-	78	100	62	-	M24	M36x1.5	
ER 50x150	50	ER50	10.0	34.0	-	78	150	112	-	M24	M36x1.5	

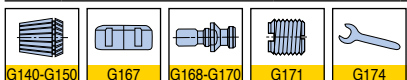

• Патроны с подводом СОЖ через фланец, имеют дополнительное буквенное обозначение - В

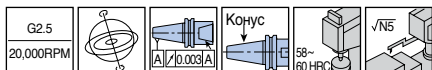
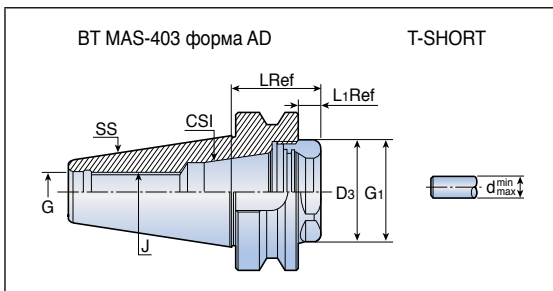

Обозначение	Размеры (мм)									
	SS	CSI	d _{мин.}	d _{макс.}	D ₃	L	L ₁	G	G ₁	J
BT30 ER 20 SHORT	30	ER20	1.0	13.0	25	27.2	5.2	M12	M25x1.5	M12
BT40 ER 32 SHORT	40	ER32	2.0	20.0	40	36.5	9.5	M16	M40x1.5	M16
ER 40 SHORT	40	ER40	3.0	26.0	50	46.5	9.5	M16	M50x1.5	M16
BT50 ER 32 SHORT	50	ER32	2.0	20.0	40	47.5	9.5	M24	M40x1.5	M22x1.5
ER 40 SHORT	50	ER40	3.0	26.0	50	47.5	9.5	M24	M50x1.5	M28x1.5

• Патроны с подводом СОЖ через фланец, имеют дополнительное буквенное обозначение - В

BT-ER-CLICK-IN

T-CLICK

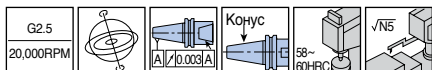
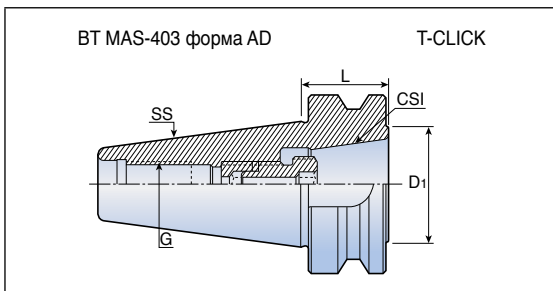

Обозначение	Размеры (мм)				
	SS	CSI	D ₁	L	G
BT40 ER32 CLICK-IN	40	SRF32	41	28	M16
BT50 ER32 CLICK-IN	50	SRF32	41	29	M24

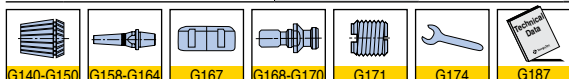

• Затяжное усилие: 24kgxm / 24 кгс*м

BT-TSK

Цанговый патрон TSK

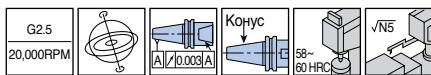
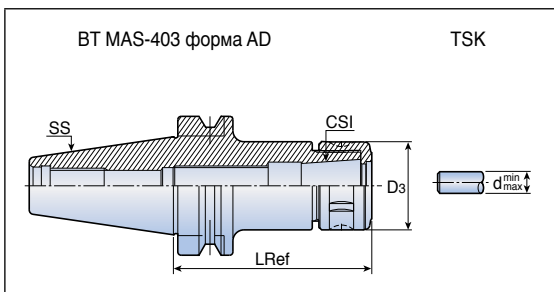

Обозначение	Размеры (мм)					
	SS	CSI	d _{мин.}	d _{макс.}	D _з	L
BT30 TSK 6-90 ⁽¹⁾	30	TSK6	1.0	6.0	19.5	90
TSK 10-90 ⁽¹⁾	30	TSK10	2.0	10.0	27.5	90
BT40 TSK 6-90	40	TSK6	1.0	6.0	19.5	90
TSK 6-120	40	TSK6	1.0	6.0	19.5	120
TSK 10-90	40	TSK10	2.0	10.0	27.5	90
TSK 10-120	40	TSK10	2.0	10.0	27.5	120
TSK 16-90	40	TSK16	3.0	16.0	40.0	90
TSK 16-120	40	TSK16	3.0	16.0	40.0	120
TSK 25-90	40	TSK25	8.0	25.4	55.0	90
TSK 25-120	40	TSK25	8.0	25.4	55.0	120
BT50 TSK 6-120 ⁽¹⁾	50	TSK6	1.0	6.0	19.5	120
TSK 6-165 ⁽¹⁾	50	TSK6	1.0	6.0	19.5	165
TSK 6-195 ⁽¹⁾	50	TSK6	1.0	6.0	19.5	195
TSK 10-120 ⁽¹⁾	50	TSK10	2.0	10.0	27.5	120
TSK 10-165 ⁽¹⁾	50	TSK10	2.0	10.0	27.5	165
TSK 10-195 ⁽¹⁾	50	TSK10	2.0	10.0	27.5	195
TSK 16-120 ⁽¹⁾	50	TSK16	3.0	16.0	40.0	120
TSK 16-165 ⁽¹⁾	50	TSK16	3.0	16.0	40.0	165
TSK 16-195 ⁽¹⁾	50	TSK16	3.0	16.0	40.0	195
TSK 25-120 ⁽¹⁾	50	TSK25	8.0	25.4	55.0	120
TSK 25-165 ⁽¹⁾	50	TSK25	8.0	25.4	55.0	165
TSK 25-195 ⁽¹⁾	50	TSK25	8.0	25.4	55.0	195

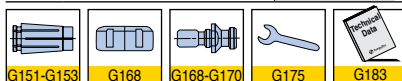

- Патроны с подводом СОЖ через фланец, имеют дополнительное буквенное обозначение - В
- (1) Балансировка G6,3 при 12000 об./мин.

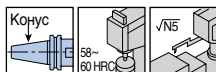
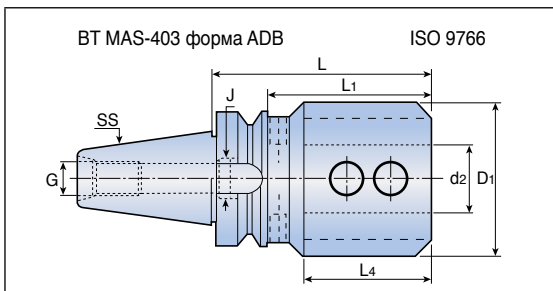

Обозначение	Размеры (мм)							
	SS	d ₂	D ₁	L	L ₁	L ₄	G	J
FITBORE BT40 EM16 ADB	40	16	72	123.5	96.5	71	M16	M10
EM20 ADB	40	20	72	123.5	96.5	71	M16	M10
EM25 ADB	40	25	72	123.5	96.5	71	M16	M10
EM32 ADB	40	32	72	123.5	96.5	71	M16	M10
EM40 ADB	40	40	72	123.5	96.5	71	M16	M10
FITBORE BT50 EM20 ADB	50	20	72	134.5	96.5	71	M24	M10
EM25 ADB	50	25	72	134.5	96.5	71	M24	M10
EM32 ADB	50	32	72	134.5	96.5	71	M24	M10
EM40 ADB	50	40	72	134.5	96.5	71	M24	M10

• Патроны с подводом СОЖ через фланец, имеют дополнительное буквенное обозначение - В

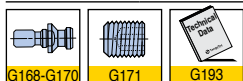

GTI BT-ER

Патрон для метчиков GTI

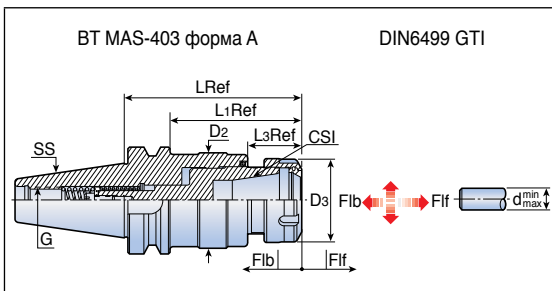
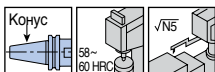

Обозначение	Размеры (мм)													
	SS	CSI	Тармин.	Тармакс.	dмин.	dмакс.	D2	D3	L	L1	L3	Fif	Fib	G
GTI BT40 ER16	40	ER16	M3	M10	0.5	10.0	29.5	28	84.2	52.7	24.6	8	3	M16
ER32	40	ER32	M6	M20	2.0	20.0	56.5	50	106.8	79.8	33.0	9	4	M16
ER40	40	ER40	M6	M28	3.0	26.0	56.5	63	124.8	97.8	51.0	9	4	M16
GTI BT50 ER16	50	ER16	M3	M10	0.5	10.0	29.5	28	106.8	68.8	24.6	8	3	M24
ER32	50	ER32	M6	M20	2.0	20.0	56.5	50	114.2	77.2	33.0	9	4	M24
ER40	50	ER40	M6	M28	3.0	26.0	56.5	63	133.2	95.2	51.0	9	4	M24

• Нельзя подавать СОЖ через патрон - это приведет к поломке.

BT-TC

Патрон для метчиков

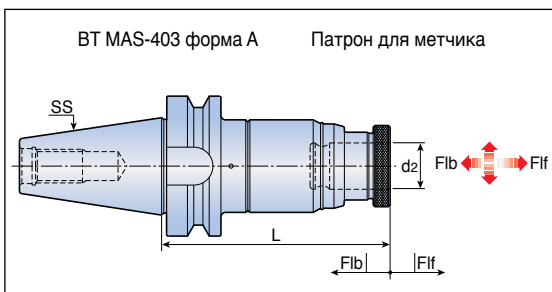
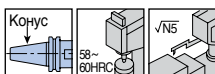

Обозначение	Размеры (мм)								Адаптер для метчиков
	SS	Тармин.	Тармакс.	d2	L	Fib	Fif		
BT30 TC 12-105	30	M3	M12	19	105	6.5	12	TA1	
BT40 TC 12-95	40	M3	M12	19	95	6.5	12	TA1	
TC 12-110	40	M3	M12	19	110	6.5	12	TA1	
TC 22-127	40	M6	M24	31	127	14.5	13	TA2	
BT50 TC 12-125	50	M6	M12	19	125	6.5	12	TA1	
TC 22-142	50	M6	M24	31	142	14.5	13	TA2	
TC 38-195	50	M18	M38	48	195	20.0	20	TA3	

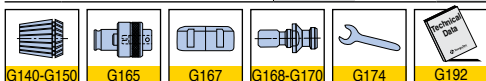

BT-TMC

Фрезерный патрон

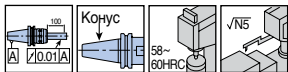
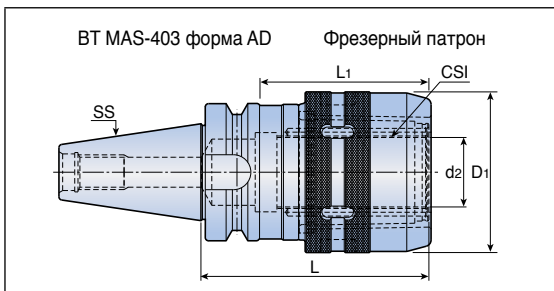

Обозначение	Размеры (мм)					
	SS	CSI	d2	D1	L	L1
BT30 TMC 20-75	30	20	20	54.0	75	53
TMC 25-80	30	25	25	62.5	80	58
BT40 TMC 20-80	40	20	20	54.0	80	53
TMC 20-105	40	20	20	54.0	105	78
TMC 25-90	40	25	25	62.5	90	63
TMC 25-105	40	25	25	62.5	105	78
TMC 32-90	40	32	32	74.0	90	63
TMC 32-105	40	32	32	74.0	105	78
TMC 32-135	40	32	32	74.0	135	108
BT50 TMC 20-105	50	20	20	54.0	105	67
TMC 20-135	50	20	20	54.0	135	97
TMC 20-165	50	20	20	54.0	165	127
TMC 25-105	50	25	25	62.5	105	67
TMC 25-135	50	25	25	62.5	135	97
TMC 25-165	50	25	25	62.5	165	127
TMC 32-105	50	32	32	74.0	105	67
TMC 32-115	50	32	32	74.0	115	77
TMC 32-135	50	32	32	74.0	135	97
TMC 32-165	50	32	32	74.0	165	127
TMC 42-115	50	42	42	92.0	115	77
TMC 42-135	50	42	42	92.0	135	97
TMC 42-165	50	42	42	92.0	165	127

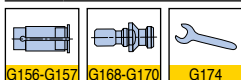

• Ключ в комплект не входит

BT-EM

Укороченный патрон Weldon для концевых фрез



BT MAS-403 форма AD DIN6359 / DIN1835 форма B

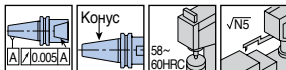
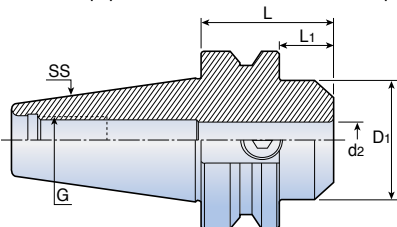

Обозначение	Размеры (мм)					
	SS	d ₂	D ₁	L	L ₁	G
BT40 EM 10x45	40	10	35	45	18	M16
EM 12x45	40	12	42	45	18	M16
EM 14x45	40	14	44	45	18	M16
EM 16x45	40	16	48	45	18	M16
EM 18x45	40	18	50	45	18	M16
EM 20x45	40	20	52	45	18	M16
EM 25x45	40	25	63	45	-	M16

• Патроны с подводом СОЖ через фланец, имеют дополнительное буквенное обозначение - В

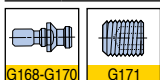

G168-G170

G171

BT-EM

Патрон Weldon для концевых фрез

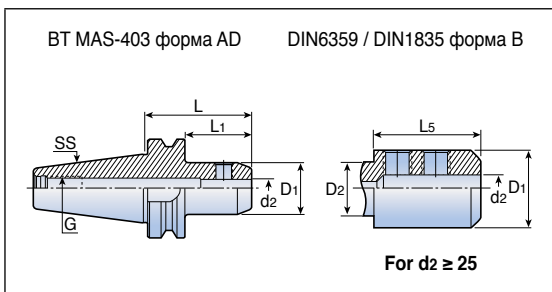
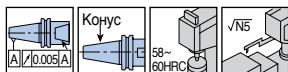

Обозначение	Размеры (мм)							
	SS	d ₂	D ₁	D ₂	L	L ₁	L ₅	G
BT30 EM 6x50	30	6	25	-	50	28	-	M12
EM 8x60	30	8	28	-	60	38	-	M12
EM 10x60	30	10	35	-	60	38	-	M12
EM 12x60	30	12	42	-	60	38	-	M12
EM 14x60	30	14	44	-	60	38	-	M12
EM 16x60	30	16	46	-	60	38	-	M12
EM 18x60	30	18	50	-	60	38	-	M12
EM 20x80	30	20	52	-	80	58	-	M12
BT40 EM 6x50	40	6	25	-	50	23	-	M16
EM 8x50	40	8	28	-	50	23	-	M16
EM 10x65	40	10	35	-	65	38	-	M16
EM 12x65	40	12	42	-	65	38	-	M16
EM 14x65	40	14	44	-	65	38	-	M16
EM 16x65	40	16	48	-	65	38	-	M16
EM 18x65	40	18	50	-	65	38	-	M16
EM 20x75	40	20	52	-	75	48	-	M16
EM 25x105	40	25	65	61	105	78	68	M16
EM 32x110	40	32	72	61	110	83	73	M16
BT50 EM 6x70	50	6	25	-	70	32	-	M24
EM 8x70	50	8	28	-	70	32	-	M24
EM 10x70	50	10	35	-	70	32	-	M24
EM 12x100	50	12	42	-	100	62	-	M24
EM 14x100	50	14	44	-	100	62	-	M24
EM 16x100	50	16	48	-	100	62	-	M24
EM 18x100	50	18	50	-	100	62	-	M24
EM 20x100	50	20	52	-	100	62	-	M24
EM 25x115	50	25	65	-	115	77	-	M24
EM 32x115	50	32	72	-	115	77	-	M24
EM 40x115	50	40	90	-	115	77	-	M24
EM 50x125	50	50	100	-	125	87	-	M24

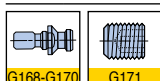

• Патроны с подводом СОЖ через фланец, имеют дополнительное буквенное обозначение - В

BT-EM-E

Патрон для концевых фрез - Whistle notch

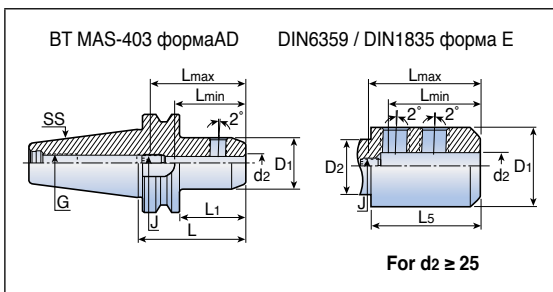
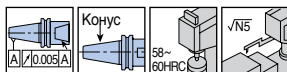

Обозначение	Размеры (мм)											
	SS	d2	D1	D2	L	L _{мин.}	L _{макс.}	L1	L5	G	J	Шестигранник
BT40 EM 6x50E	40	6	25	-	50	35	45	23	-	M16	M5	2.5
EM 10x65E	40	10	35	-	65	39	49	38	-	M16	M8	4.0
EM 12x65E	40	12	42	-	65	44	54	38	-	M16	M10	5.0
EM 14x65E	40	14	44	-	65	44	54	38	-	M16	M10	5.0
EM 16x65E	40	16	48	-	65	47	57	38	-	M16	M12	6.0
EM 18x65E	40	18	50	-	65	47	57	38	-	M16	M12	6.0
EM 20x75E	40	20	52	-	75	49	59	48	-	M16	M16	8.0
EM 25x105E	40	25	65	61	105	54	64	78	68	M16	M20x1.5	10.0
EM 32x110E	40	32	72	61	110	58	68	83	73	M16	M20x1.5	10.0
BT50 EM 6x70E	50	6	25	-	70	35	45	32	-	M24	M5	2.5
EM 10x70E	50	10	35	-	70	39	49	32	-	M24	M8	4.0
EM 12x100E	50	12	42	-	100	44	54	62	-	M24	M10	5.0
EM 14x100E	50	14	44	-	100	44	54	62	-	M24	M10	5.0
EM 16x100E	50	16	48	-	100	47	57	62	-	M24	M12	6.0
EM 18x100E	50	18	50	-	100	47	57	62	-	M24	M12	6.0
EM 20x100E	50	20	52	-	100	49	59	62	-	M24	M16	8.0
EM 25x115E	50	25	65	-	115	54	64	77	-	M24	M20x1.5	10.0
EM 32x115E	50	32	72	-	115	58	68	77	-	M24	M20x1.5	10.0
EM 40x115E	50	40	90	-	115	68	78	77	-	M24	M20x1.5	10.0
EM 50x125E	50	50	98	-	125	78	88	67	-	M24	M20x1.5	10.0

• Патроны с подводом СОЖ через фланец, имеют дополнительное буквенное обозначение - В

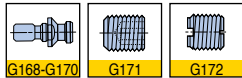

Термо патрон для твердосплавных и стальных хвостовиков

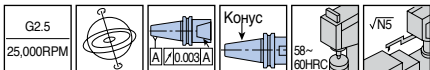
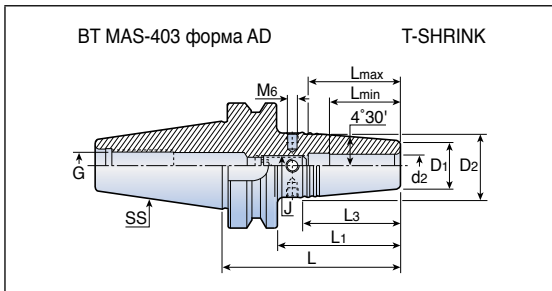

Обозначение	Размеры (мм)												
	SS	d ₂	D ₁	D ₂	L	L _{мин.}	L _{макс.}	L ₁	L ₃	G	J	Шестиграннык	
BT40 SRKIN 6x90	40	6	21	27	90	25	36	63	38.0	M16	M5	2.5	
SRKIN 8x90	40	8	21	27	90	25	36	63	38.0	M16	M6	3.0	
SRKIN 10x90	40	10	24	32	90	31	42	63	50.5	M16	M8	4.0	
SRKIN 12x90	40	12	24	32	90	36	47	63	50.5	M16	M10	5.0	
SRKIN 14x90	40	14	27	34	90	36	47	63	44.5	M16	M10	5.0	
SRKIN 16x90	40	16	27	34	90	39	50	63	44.5	M16	M12	6.0	
SRKIN 18x90	40	18	33	42	90	39	50	63	57.0	M16	M12	6.0	
SRKIN 20x90	40	20	33	42	90	41	52	63	57.0	M16	M16	8.0	
SRKIN 25x110	40	25	44	53	110	47	58	83	57.0	M16	M16	8.0	
BT50 SRKIN 6x100⁽¹⁾	50	6	21	26	100	25	36	62	32.0	M24	M5	2.5	
SRKIN 8x100⁽¹⁾	50	8	21	27	100	25	36	62	38.0	M24	M6	3.0	
SRKIN 10x100⁽¹⁾	50	10	24	32	100	31	42	62	51.0	M24	M8	4.0	
SRKIN 12x100⁽¹⁾	50	12	24	32	100	36	47	62	51.0	M24	M10	5.0	
SRKIN 14x100⁽¹⁾	50	14	27	34	100	36	47	62	44.5	M24	M10	5.0	
SRKIN 16x100⁽¹⁾	50	16	27	34	100	39	50	62	44.5	M24	M12	6.0	
SRKIN 18x100⁽¹⁾	50	18	33	42	100	39	50	62	57.0	M24	M12	6.0	
SRKIN 20x100⁽¹⁾	50	20	33	42	100	41	52	62	57.0	M24	M16	8.0	
SRKIN 25x120⁽¹⁾	50	25	44	53	120	47	58	82	57.0	M24	M16	8.0	
SRKIN 32x120⁽¹⁾	50	32	44	53	120	47	58	82	57.0	M24	M16	8.0	



• ⁽¹⁾ Балансировка G6,3 при 12000 об./мин.

Термо патрон для твердосплавных хвостовиков

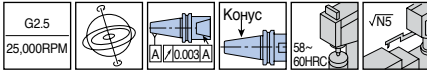
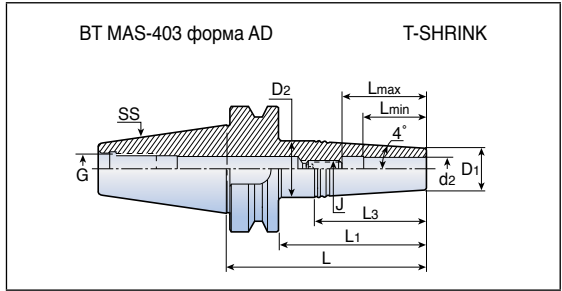

Обозначение	Размеры (мм)											
	SS	d2	D1	D2	L	L _{мин.}	L _{макс.}	L1	L3	G	J	Шестигранник
BT40 SRK 3x50	40	3	10	15.0	77	10	16	50	35.5	M16	M6	3.0
SRK 3x85	40	3	10	19.0	112	10	16	85	64.1	M16	M6	3.0
SRK 4x50	40	4	10	15.0	77	12	18	50	35.5	M16	M6	3.0
SRK 4x85	40	4	10	19.0	112	12	18	85	64.1	M16	M6	3.0
SRK 5x50	40	5	10	15.0	77	15	21	50	35.5	M16	M6	3.0
SRK 5x85	40	5	10	19.0	112	15	21	85	64.1	M16	M6	3.0
SRK 6x50	40	6	11	16.0	77	18	24	50	35.5	M16	M8	4.0
SRK 6x85	40	6	11	20.0	112	18	24	85	64.1	M16	M8	4.0
SRK 8x50	40	8	14	20.0	77	25	31	50	42.5	M16	M10	5.0
SRK 8x85	40	8	14	23.0	112	25	31	85	63.9	M16	M10	5.0
SRK 10x50	40	10	16	22.0	77	30	36	50	42.4	M16	M12	6.0
SRK 10x85	40	10	16	24.5	112	30	36	85	60.2	M16	M12	6.0
SRK 12x50	40	12	20	26.0	77	32	42	50	42.3	M16	M10	5.0
SRK 12x85	40	12	20	28.0	112	32	42	85	56.6	M16	M10	5.0

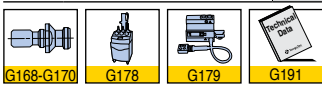

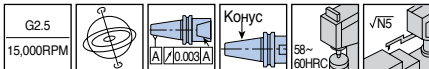
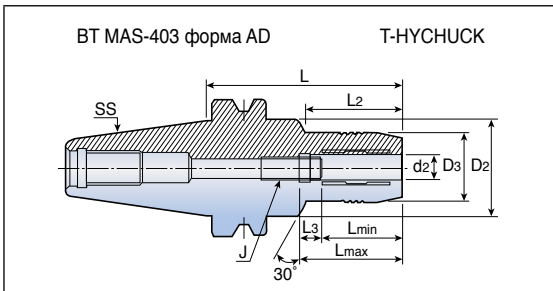

Обозначение	Размеры (мм)									
	SS	d2	D2	D3	L	L _{мин.}	L _{макс.}	L2	L3	J
BT 30 THC 6-70 ⁽¹⁾	30	6	45	28	70	27.5	37.5	28.0	10	M5
THC 8-70 ⁽¹⁾	30	8	45	30	70	27.5	37.5	28.0	10	M6
THC 10-75 ⁽¹⁾	30	10	45	32	75	32.5	42.5	38.0	10	M8x1
THC 12-85 ⁽¹⁾	30	12	45	34	85	37.5	47.5	44.0	10	M10x1
THC 14-85 ⁽¹⁾	30	14	45	36	85	37.5	47.5	44.0	10	M10x1
THC 16-90 ⁽¹⁾	30	16	45	38	90	42.5	52.5	46.0	10	M10x1
THC 20-85 ⁽¹⁾	30	20	45	43	85	42.5	52.5	63.0	10	M10x1
THC 20-90 ⁽¹⁾	30	20	45	41	90	42.5	52.5	68.0	10	M10x1
BT 40 THC 6-65	40	6	50	28	65	27.5	37.5	23.0	10	M5
THC 6-95	40	6	50	28	65	27.5	37.5	43.0	10	M5
THC 8-95	40	8	50	30	95	27.5	37.5	44.0	10	M6
THC 10-95	40	10	50	32	95	32.5	42.5	44.0	10	M8x1
THC 12-95	40	12	50	34	95	37.5	47.5	44.0	10	M10x1
THC 14-95	40	14	50	36	95	37.5	47.5	44.0	10	M10x1
THC 16-95	40	16	50	38	95	42.5	52.5	46.0	10	M10x1
THC 16-140	40	16	50	38	140	42.5	52.5	47.5	10	M10x1
THC 20-95	40	20	50	43	95	42.5	52.5	48.0	10	M10x1
THC 25-100	40	25	-	57	100	51.0	61.0	73.0	10	M16x1
THC 25-135	40	25	-	57	135	51.0	61.0	108.0	10	M16x1
THC 32-105	40	32	-	63	105	55.0	61.0	78.0	10	M16x1

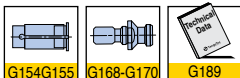

• ⁽¹⁾ Балансировка G6,3 при 12000 об./мин.

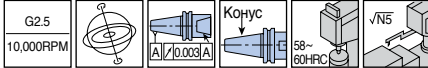
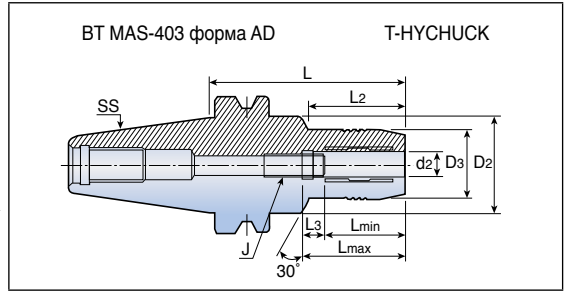

Обозначение	Размеры (мм)										
	SS	d2	D2	D3	L	L _{мин.}	L _{макс.}	L2	L3	J	
BT50 THC 6-90	50	6	50	28	90	27.5	37.5	32	10	M5	
THC 6-120	50	6	50	28	120	27.5	37.5	38	10	M5	
THC 10-90	50	10	50	32	90	32.5	42.5	32	10	M8x1	
THC 10-120	50	10	50	32	120	32.5	42.5	42	10	M8x1	
THC 12-90	50	12	50	34	90	47.5	47.5	32	10	M8x1	
THC 12-120	50	12	50	34	120	47.5	47.5	44	10	M8x1	
THC 14-90	50	14	50	36	90	47.5	47.5	32	10	M10x1	
THC 16-90	50	16	50	38	90	42.5	52.5	32	10	M10x1	
THC 20-90	50	20	50	43	90	42.5	52.5	32	10	M10x1	
THC 20-120	50	20	50	43	120	42.5	52.5	48	10	M10x1	
THC 20-140	50	20	50	43	140	42.5	52.5	48	10	M10x1	
THC 25-105	50	25	-	57	105	51.0	61.0	67	10	M16x1	
THC 25-150	50	25	-	57	150	51.0	61.0	112	10	M16x1	
THC 32-90	50	32	-	63	90	55.0	65.0	52	10	M16x1	
THC 32-115	50	32	-	63	115	55.0	65.0	77	10	M16x1	
THC 32-135	50	32	-	63	135	55.0	65.0	97	10	M16x1	
THC 32-150	50	32	-	63	150	55.0	65.0	112	10	M16x1	

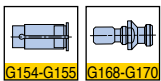

BT-SCA

Оправка для дисковых фрез

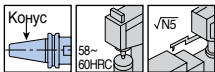
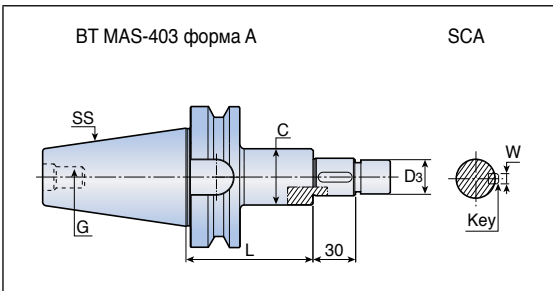

Обозначение	Размеры (мм)					
	SS	D3	L	C	W	G
BT40 - SCA-22(22.225)-75	40	22(22.225)	75	34	6(3.18)	M16
SCA-22-120	40	22	120	34	6(3.18)	M16
SCA-27(25.4)-75	40	27(25.4)	75	40	7(6.35)	M16
SCA-27-120	40	27	120	40	7(6.35)	M16
SCA-32(31.75)-90	40	32(31.75)	90	46	8(7.92)	M16
SCA-22(22.225)-90	40	22(22.225)	90	34	6(3.18)	M24
BT50 - SCA-22-135	50	22	135	34	6(3.18)	M24
SCA-27(25.4)-90	50	27(25.4)	90	40	7(6.35)	M24
SCA-27-135	50	27	135	40	7(6.35)	M24
SCA-32(31.75)-90	50	32(31.75)	90	46	8(7.92)	M24
SCA-40(38.1)-90	50	40(38.1)	90	55	10(9.52)	M24
SCA-50-90	50	50	90	68	12	M24



• Регулировочные кольца и ключ входят в комплект (Соответственно 3, 5, 7, 8, 10, 12мм)

BT-SEM

Оправка для торцевых/насадных фрез

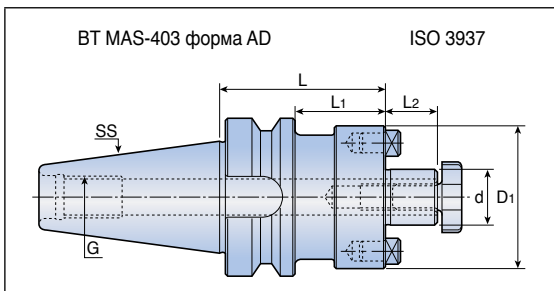
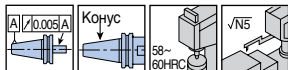

Обозначение	Размеры (мм)						
	SS	d	D1	L	L1	L2	G
BT30 SEM 16x50	30	16	38	50	28	17	M12
SEM 22x50	30	22	47	50	28	19	M12
SEM 27x50	30	27	58	50	18	21	M12
BT40 SEM 16x60	40	16	38	60	33	17	M16
SEM 16x120	40	16	38	120	93	17	M16
SEM 22x60	40	22	47	60	33	19	M16
SEM 22x120	40	22	47	120	93	19	M16
SEM 27x45	40	27	58	45	18	21	M16
SEM 27x105	40	27	58	105	78	21	M16
SEM 32x60	40	32	65	60	23	24	M16
SEM 32x75	40	32	65	75	36	24	M16
SEM 40x60	40	40	82	60	23	27	M16
SEM 40x75	40	40	82	75	38	27	M16
BT50 SEM 16x75	50	16	38	75	37	17	M24
SEM 16x120	50	16	38	120	82	17	M24
SEM 22x50x220	50	22	50	220	182	19	M24
SEM 22x64x320	50	22	64	320	282	19	M24
SEM 22x75	50	22	47	75	37	19	M24
SEM 22x120	50	22	47	120	82	19	M24
SEM 27x60	50	27	58	60	22	21	M24
SEM 27x105	50	27	58	105	67	21	M24
SEM 32x48	50	32	66	48	10	24	M24
SEM 32x75	50	32	66	75	37	24	M24
SEM 40x48	50	40	82	48	10	27	M24
SEM 40x75	50	40	82	75	37	27	M24



• Ключ не входит в поставку

BT-SEM-C

Оправка для торцевых фрез со подачей СОЖ

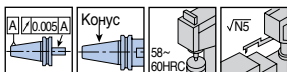
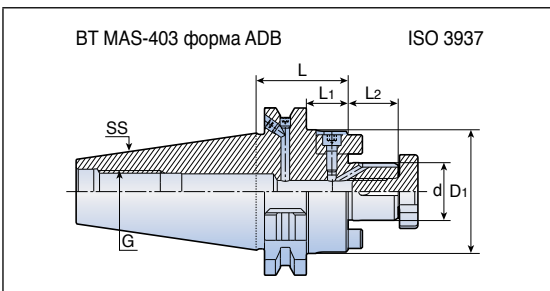

Обозначение	Размеры (мм)						
	SS	d	D1	L	L1	L2	G
BT40 SEM 16x60C	40	16	38	60	17	33	M16
SEM 16x100C	40	16	38	100	17	73	M16
SEM 22x60C	40	22	47	60	19	33	M16
SEM 22x100C	40	22	47	100	19	73	M16
SEM 27x45C	40	27	58	45	21	18	M16
SEM 27x100C	40	27	58	100	21	73	M16
SEM 32x60C	40	32	66	60	24	33	M16
BT50 SEM 16x75C	50	16	38	75	17	37	M24
SEM 16x100C	50	16	38	100	17	62	M24
SEM 22x75C	50	22	47	75	19	37	M24
SEM 22x100C	50	22	47	100	19	62	M24
SEM 27x60C	50	27	58	60	21	22	M24
SEM 27x100C	50	27	58	100	21	62	M24
SEM 32x75C	50	32	66	75	24	37	M24
SEM 32x100C	50	32	66	100	24	62	M24
BT50 SEM 22x48x220C	50	22	48	220	182	19	M24
SEM 22x61x320C	50	22	61	320	282	19	M24
SEM 27x61x320C	50	27	61	320	282	21	M24
SEM 32x78x390C	50	32	78	390	352	24	M24



- Если требуется тип В, из фланцевого отверстия подачи СОЖ извлекается запорный винт (Используйте шестигранник 2 мм)
- Ключ не входит в поставку

BT-SEMC

Комбинированная оправка для насадных/дисковых фрез

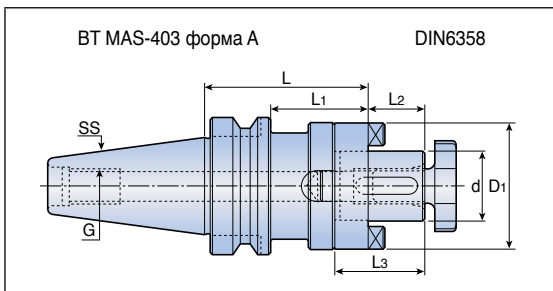
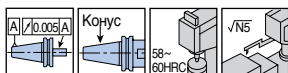

Обозначение	Размеры (мм)							
	SS	d	D1	L	L1	L2	L3	G
BT40 SEMC 16x50	40	16	32	50	23	17	27	M16
SEMC 16x100	40	16	32	100	73	17	27	M16
SEMC 22x53	40	22	40	53	26	19	31	M16
SEMC 22x100	40	22	40	100	73	19	31	M16
SEMC 27x55	40	27	48	55	28	21	33	M16
SEMC 27x100	40	27	48	100	73	21	33	M16
SEMC 32x60	40	32	58	60	33	24	38	M16
SEMC 32x100	40	32	58	100	73	24	38	M16
SEMC 40x80	40	40	70	80	53	27	41	M16
BT50 SEMC 16x100	50	16	32	100	62	17	27	M24
SEMC 16x150	50	16	32	150	112	17	27	M24
SEMC 22x68	50	22	40	68	30	19	31	M24
SEMC 22x100	50	22	40	100	62	19	31	M24
SEMC 22x150	50	22	40	150	112	19	31	M24
SEMC 27x78	50	27	48	78	40	21	33	M24
SEMC 27x100	50	27	48	100	62	21	33	M24
SEMC 27x150	50	27	48	150	112	21	33	M24
SEMC 32x78	50	32	58	78	40	24	38	M24
SEMC 32x100	50	32	58	100	62	24	38	M24
SEMC 32x150	50	32	58	150	112	24	38	M24
SEMC 40x78	50	40	70	78	40	27	41	M24
SEMC 40x100	50	40	70	100	62	27	41	M24
SEMC 40x150	50	40	70	150	112	27	41	M24
SEMC 50x79	50	50	90	79	41	30	46	M24
SEMC 50x150	50	50	90	150	112	30	46	M24

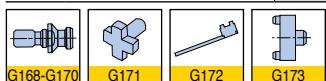

• Ключ не входит в поставку

BT-FMA

Оправка для торцевых фрез

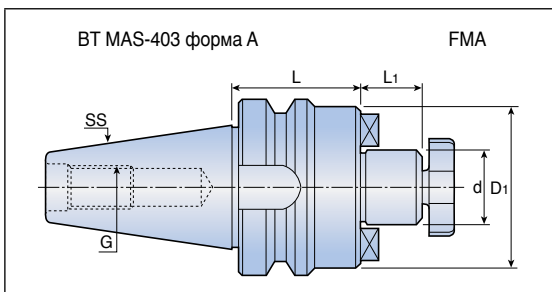
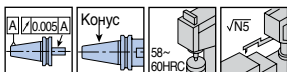

Обозначение	Размеры (мм)						
	SS	d	D1	L	L1	G	Крепежный болт
BT30 FMA 25.4-45L	30	25.400	50.00	45	22	M12	MBA M12
BT40 FMA 25.4-45L	40	25.400	50.00	45	22	M16	MBA M12
FMA 25.4-90L	40	25.400	50.00	90	22	M16	MBA M12
FMA 31.75-45L	40	31.750	60.00	45	30	M16	MBA M16
FMA 31.75-75L	40	31.750	60.00	75	30	M16	MBA M16
FMA 38.1-60L	40	38.100	80.00	60	34	M16	MBA M20
BT50 FMA 25.4-45L	50	25.400	50.00	45	22	M24	MBA M12
FMA 25.4-90L	50	25.400	50.00	90	22	M24	MBA M12
FMA 25.4-150L	50	25.400	50.00	150	22	M24	MBA M12
FMA 31.75-45L	50	31.750	60.00	45	30	M24	MBA M16
FMA 31.75-75L	50	31.750	60.00	75	30	M24	MBA M16
FMA 31.75-105L	50	31.750	60.00	105	30	M24	MBA M16
FMA 38.1-45L	50	38.100	80.00	45	34	M24	MBA M20
FMA 38.1-75L	50	38.100	80.00	75	34	M24	MBA M20
FMA 50.8-45L	50	50.800	98.00	45	36	M24	MBA M24
FMA 50.8-75L	50	50.800	98.00	75	36	M24	MBA M24
FMA 47.625-75L	50	47.625	128.57	75	38	M24	SH M16x2x40

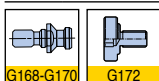

BT-MT

Оправка под конус Морзе - "лапка"

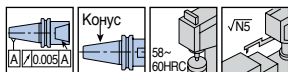
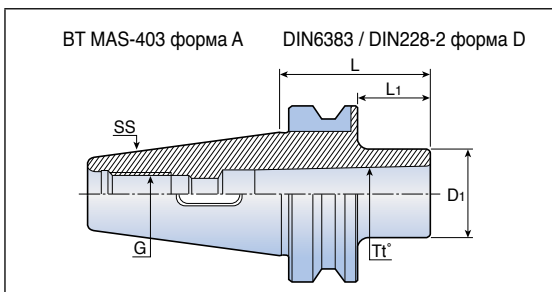

Обозначение	Размеры (мм)					
	SS	Tt°	D1	L	L1	G
BT30 MT 1x45	30	MT1	25	45	23	M12
MT 2x60	30	MT2	32	60	38	M12
BT40 MT 1x45	40	MT1	25	45	25	M16
MT 1x120	40	MT1	25	120	25	M16
MT 2x60	40	MT2	32	60	32	M16
MT 2x120	40	MT2	32	120	32	M16
MT 3x75	40	MT3	40	75	40	M16
MT 3x139	40	MT3	40	139	40	M16
MT 4x95	40	MT4	50	95	50	M16
BT50 MT 1x45	50	MT1	25	45	7	M24
MT 1x120	50	MT1	25	120	82	M24
MT 2x45	50	MT2	32	45	7	M24
MT 2x135	50	MT2	32	135	97	M24
MT 2x180	50	MT2	32	180	142	M24
MT 3x45	50	MT3	40	45	7	M24
MT 3x150	50	MT3	40	150	112	M24
MT 3x180	50	MT3	40	180	142	M24
MT 4x75	50	MT4	50	75	37	M24
MT 4x180	50	MT4	50	180	142	M24
MT 5x105	50	MT5	70	105	67	M24



BT-MT-DRW

Оправка под конус Морзе - резьба

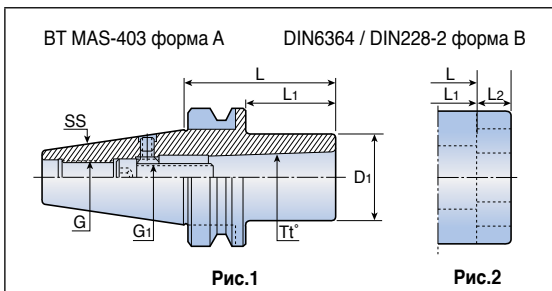
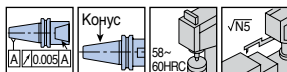

Обозначение	Размеры (мм)								Рис.
	SS	Tt°	D1	L	L1	L2	G	G1	
BT40 MT1 DRW	40	MT1	25	50	23	-	M16	M6	1
MT2 DRW	40	MT2	32	50	23	-	M16	M10	1
MT3 DRW	40	MT3	40	70	43	-	M16	M12	1
MT4 DRW⁽¹⁾	40	MT4	63	95	68	15	M16	M16	2
BT50 MT1 DRW	50	MT1	25	45	7	-	M24	M6	1
MT2 DRW	50	MT2	32	60	22	-	M24	M10	1
MT3 DRW	50	MT3	40	65	27	-	M24	M12	1
MT4 DRW⁽¹⁾	50	MT4	63	70	32	15	M24	M16	2
MT5 DRW⁽¹⁾	50	MT5	78	100	62	18	M24	M20	2

• ⁽¹⁾ DIN2201

BT-AD

Переходная оправка

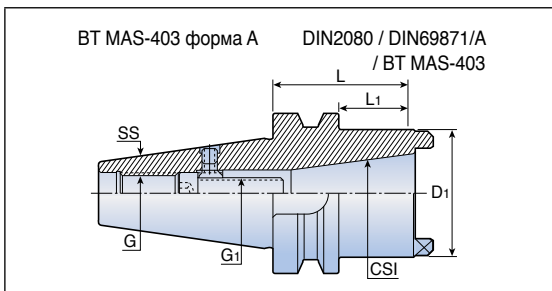
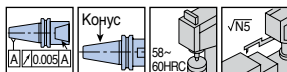

Обозначение	Размеры (мм)						
	SS	CSI	L	L1	D1	G	G1
BT50 AD 40	50	DIN 2080	75	32	63	M24	M16
AD BT/SK 40	50	DIN 69871/A, BT MAS	75	37	66	M24	M16



BT-DC

Оправка для сверлильных патронов

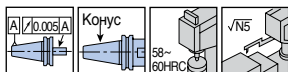
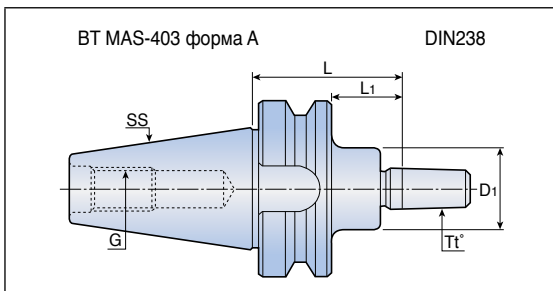

Обозначение	Размеры (мм)					
	SS	Tt°	L	D1	L1	G
BT30 DC B12x30	30	B12	30	-	8.0	M12
DC B16x30	30	B16	30	-	8.0	M12
BT40 DC B12x45	40	B12	45	24	18.0	M16
DC B12x90	40	B12	90	24	63.0	M16
DC B16x45	40	B16	45	30	18.0	M16
DC B16x90	40	B16	90	30	63.0	M16
DC B18x45	40	B18	45	30	18.0	M16
DC B18x90	40	B18	90	30	63.0	M16
BT50 DC B12x45	50	B12	45	-	6.7	M24
DC B12x105	50	B12	105	24	67.0	M24
DC B16x45	50	B16	45	-	7.0	M24
DC B16x105	50	B16	105	50	67.0	M24
DC B18x45	50	B18	45	-	7.0	M24
DC B18x105	50	B18	105	30	67.0	M24



• Без сверлильного патрона

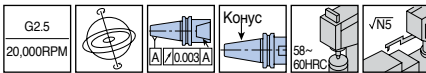
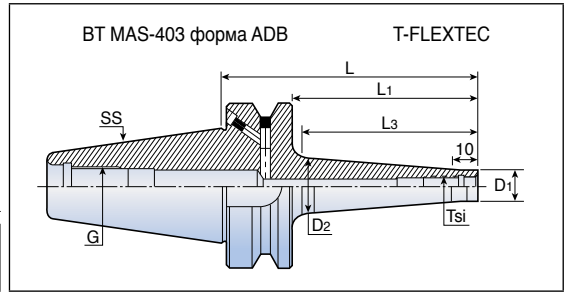

Обозначение	Размеры (мм)							
	SS	Tsi	D1	D2	L	L1	L3	G
BT40 ODP 6x66	40	M6	9.8	13.0	66	39	30	M16
ODP 6x106	40	M6	9.8	23.0	106	79	70	M16
ODP 8x66	40	M8	13.0	15.0	66	39	30	M16
ODP 8x106	40	M8	13.0	23.0	106	79	70	M16
ODP 10x66	40	M10	18.0	20.0	66	39	30	M16
ODP 10x106	40	M10	18.0	28.0	106	79	70	M16
ODP 12x66	40	M12	21.0	24.0	66	39	30	M16
ODP 12x106	40	M12	21.0	31.0	106	79	70	M16
ODP 16x66	40	M16	29.0	28.6	66	39	35	M16
ODP 16x106	40	M16	29.0	34.0	106	79	70	M16
BT50 ODP 12x94⁽¹⁾	50	M12	23.0	30.0	94	56	50	M24
ODP 12x144⁽¹⁾	50	M12	23.0	40.0	144	106	100	M24
ODP 12x194⁽¹⁾	50	M12	23.0	40.0	194	156	150	M24
ODP 12x244⁽¹⁾	50	M12	23.0	46.0	244	206	200	M24
ODP 16x94⁽¹⁾	50	M16	29.0	34.0	94	56	50	M24
ODP 16x144⁽¹⁾	50	M16	29.0	40.0	144	106	100	M24
ODP 16x194⁽¹⁾	50	M16	29.0	55.0	194	156	150	M24
ODP 16x244⁽¹⁾	50	M16	29.0	55.0	244	206	200	M24



- Если требуется тип В, из фланцевого отверстия подачи СОЖ извлекается запорный винт (Используйте шестигранник 2мм)
- ⁽¹⁾ Балансировка G6,3 при 12000 об./мин.

DIN2080



DIN2080

Стандартный патрон

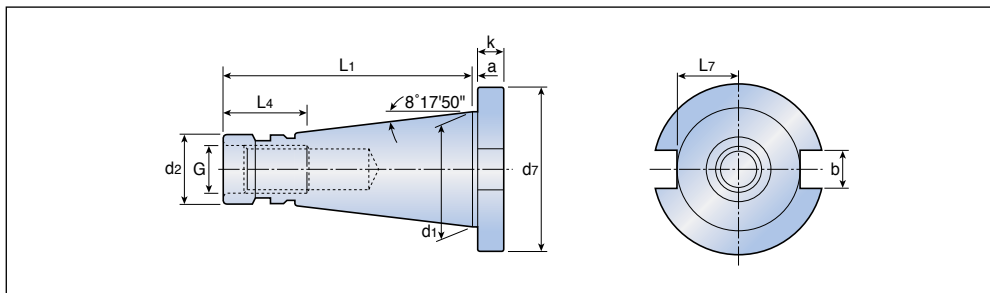

Конус	a ± 0.2	b (H12)	d1	d2	G	d7	K ± 0.15	L1	L4	L7 макс.	Конус AT3
30	1.6	16.1	31.75	17.4	M12	50.0	8	68.4	24	16.2	0.002
40	1.6	16.1	44.45	25.3	M16	63.0	10	93.4	32	22.5	0.003
50	3.2	25.7	69.85	39.6	M24	97.5	12	126.8	47	35.3	0.004

* для нескладских позиций: Поставляется в случае наличия.
 Если нет на складе, применяется MOQ (Минимальное количество заказа).

DIN2080-ER

Цанговый патрон ER

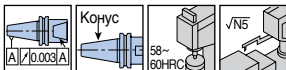
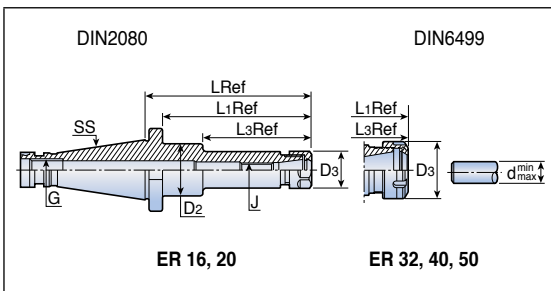

Обозначение	Размеры (мм)											
	SS	CSI	d _{мин.}	d _{макс.}	D ₃	D ₂	L	L ₁	L ₃	G	J	
DIN2080 30	ER 16x75	30	ER16	0.5	10.0	28	-	75	65.4	-	M12	M10
	ER 32x55	30	ER32	2.0	20.0	50	-	55	45.4	-	M12	M18x1.5
	ER 40x83	30	ER40	3.0	26.0	63	-	83	69.4	-	M12	M22x1.5
DIN2080 40	ER 16x63	40	ER16	0.5	10.0	28	-	63	51.4	-	M16	M12
	ER 16x100	40	ER16	0.5	10.0	28	-	100	88.4	-	M16	M12
	ER 20x63	40	ER20	1.0	13.0	34	-	63	51.4	-	M16	M12
	ER 20x100	40	ER20	1.0	13.0	34	-	100	88.4	-	M16	M12
	ER 25x50	40	ER25	1.0	16.0	42	-	50	38.4	-	M16	M16x1.5
	ER 32x50	40	ER32	2.0	20.0	50	-	50	38.4	-	M16	M22x1.5
	ER 40x55	40	ER40	3.0	26.0	63	-	55	43.4	-	M16	M22x1.5
	ER 50x80	40	ER50	10.0	34.0	78	-	80	68.4	-	M24	M22x1.5
DIN2080 50	ER 16x100	50	ER16	0.5	10.0	28	-	100	84.8	-	M24	M12
	ER 16x160	50	ER16	0.5	10.0	28	40	160	144.8	95	M24	M12
	ER 20x100	50	ER20	1.0	13.0	34	-	100	84.8	-	M24	M16
	ER 20x160	50	ER20	1.0	13.0	34	-	160	144.8	-	M24	M12
	ER 40x58	50	ER40	3.0	26.0	63	-	58	42.8	-	M24	M28x1.5
	ER 50x63	50	ER50	10.0	34.0	78	-	63	47.8	-	M24	M36x1.5

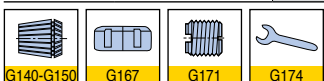

DIN2080-TMC

Фрезерный патрон

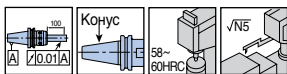
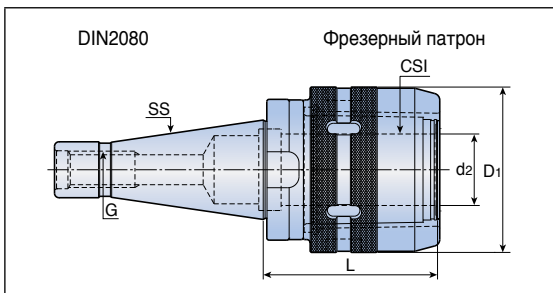

Обозначение	Размеры (мм)					
	SS	CSI	d2	D1	L	G
DIN2080 30 TMC 20-67	30	20	20	54	67	M12
DIN2080 40 TMC 25-78	40	25	25	74	78	M16
TMC 32-78	40	32	32	74	78	M16
DIN2080 50 TMC 32-85	50	32	32	74	85	M24
TMC 42-102	50	42	42	92	102	M24

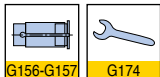

DIN2080-EM

Патрон Weldon для концевых фрез

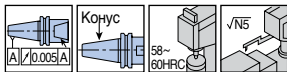
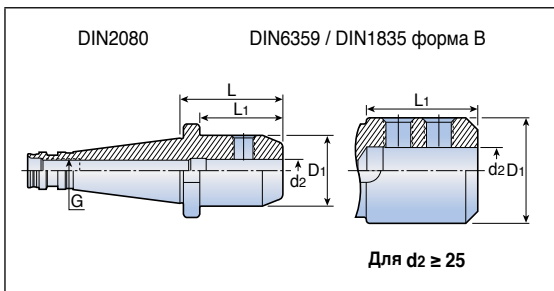

Обозначение	Размеры (мм)						
	SS	d2	D1	L	L1	G	
DIN2080 30	EM 6x40	30	6	25	40	30.4	M12
	EM 8x40	30	8	28	40	30.4	M12
	EM 10x40	30	10	35	40	30.4	M12
	EM 16x50	30	16	48	50	40.4	M12
	EM 20x63	30	20	52	63	53.4	M12
DIN2080 40	EM 6x50	40	6	25	50	38.4	M16
	EM 8x50	40	8	28	50	38.4	M16
	EM 10x50	40	10	35	50	38.4	M16
	EM 12x50	40	12	42	50	38.4	M16
	EM 16x63	40	16	48	63	51.4	M16
	EM 20x63	40	20	52	63	51.4	M16
	EM 25x80	40	25	65	80	68.4	M16
	EM 32x80	40	32	72	80	68.4	M16
	DIN2080 50	EM 6x63	50	6	25	63	47.8
EM 8x63		50	8	28	63	47.8	M24
EM 10x63		50	10	35	63	47.8	M24
EM 12x63		50	12	42	63	47.8	M24
EM 16x63		50	16	48	63	47.8	M24
EM 20x63		50	20	52	63	47.8	M24
EM 25x80		50	25	65	80	64.8	M24
EM 32x80		50	32	72	80	64.8	M24
EM 40x90		50	40	90	90	74.8	M24
EM 50x100		50	50	100	100	84.8	M24



G171

DIN2080-FM

Оправка для торцевых фрез

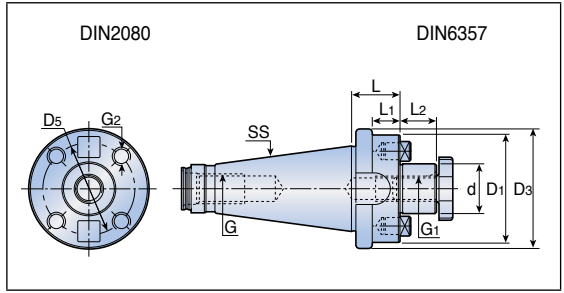
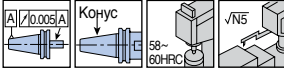

Обозначение	Размеры (мм)										
	SS	d	D1	D3	D5	L	L1	L2	G	G1	G2
DIN2080 40 FM40	40	40	66.7	88.0	66.7	20.0	-	27	M16	M20	M12
DIN2080 50 FM40	50	40	66.7	97.5	66.7	36.0	20.8	27	M24	M20	M12
FM60	50	60	101.6	128.0	101.6	35.8	-	40	M24	-	M16

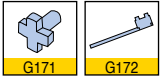

• Ключ не входит в поставку

DIN2080-SEM

Оправка для торцевых фрез

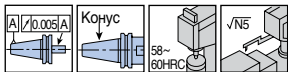
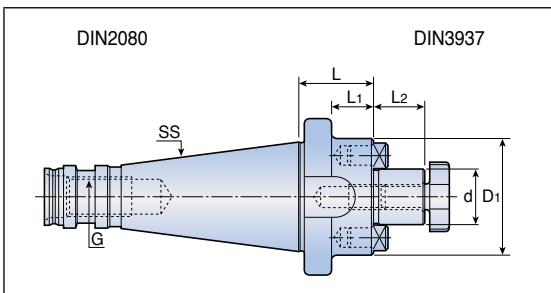

Обозначение	Размеры (мм)							
	SS	d	D1	L	L1	L2	G	
DIN2080 30 SEM 16x28	30	16	38	28	18.4	17	M12	
	30	22	47	28	18.4	19	M12	
	30	27	58	32	22.4	21	M12	
	30	32	66	32	22.4	24	M12	
DIN2080 40 SEM 16x28	40	16	38	28	16.4	17	M16	
	40	22	47	27	15.4	19	M16	
	40	27	58	26	14.4	21	M16	
	40	32	66	23	11.4	24	M16	
	40	40	82	34	22.4	27	M16	
DIN2080 50 SEM 16x38	50	16	38	38	22.8	17	M24	
	50	22	47	38	22.8	19	M24	
	50	27	58	38	22.8	21	M24	
	50	32	66	36	20.8	24	M24	
	50	40	82	40	24.8	27	M24	

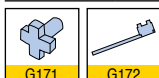

• Ключ не входит в поставку

DIN2080-SEMC

Комбинированная оправка для насадных/дисковых фрез

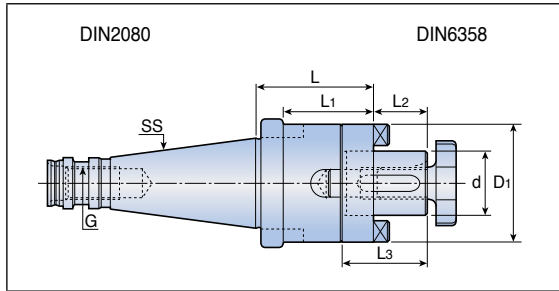
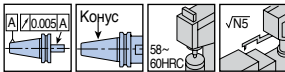

Обозначение	Размеры (мм)									
	SS	d	D1	L	L1	L2	L3	G		
DIN2080 30 SEMC 16x35	30	16	32	35	25.4	17	27	M12		
		SEMC 22x35	30	22	40	35	25.4	19	31	M12
		SEMC 27x35	30	27	48	35	25.4	21	33	M12
		SEMC 32x50	30	32	58	50	40.4	24	38	M12
DIN2080 40 SEMC 22x52	40	22	40	52	40.4	19	31	M16		
		SEMC 27x52	40	27	48	52	40.4	21	33	M16
		SEMC 32x52	40	32	58	52	40.4	24	38	M16
		SEMC 40x52	40	40	70	52	40.4	27	41	M16
DIN2080 50 SEMC 16x55	50	16	32	55	39.8	17	27	M24		
		SEMC 22x55	50	22	40	55	39.8	19	31	M24
		SEMC 27x55	50	27	48	55	39.8	21	33	M24
		SEMC 32x55	50	32	58	55	39.8	24	38	M24
		SEMC 40x55	50	40	70	55	39.8	27	41	M24
	SEMC 50x55	50	50	90	55	39.8	30	46	M24	



• Ключ не входит в поставку

DIN2080-MT

Оправка под конус Морзе - "лапка"

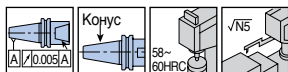
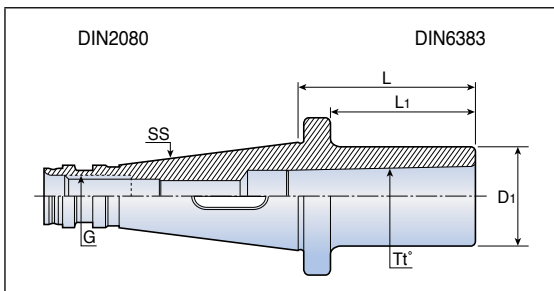

Обозначение	Размеры (мм)					
	SS	Tt°	D1	L	L1	G
DIN2080 30 MT 1x50	30	MT1	25	50	40.4	M12
MT 2x50	30	MT2	32	50	40.4	M12
MT 3x70	30	MT3	40	50	60.4	M12
DIN2080 40 MT 1x50	40	MT1	25	50	38.4	M16
MT 2x50	40	MT2	32	50	38.4	M16
MT 3x65	40	MT3	40	65	53.4	M16
MT 4x95	40	MT4	48	95	83.4	M16
DIN2080 50 MT 1x45	50	MT1	25	45	29.8	M24
MT 2x60	50	MT2	32	60	44.8	M24
MT 3x65	50	MT3	40	65	49.8	M24
MT 4x70	50	MT4	48	70	54.8	M24
MT 5x105	50	MT5	63	105	89.2	M24

DIN2080-MT-DRW

Оправка под конус Морзе - "резьба"

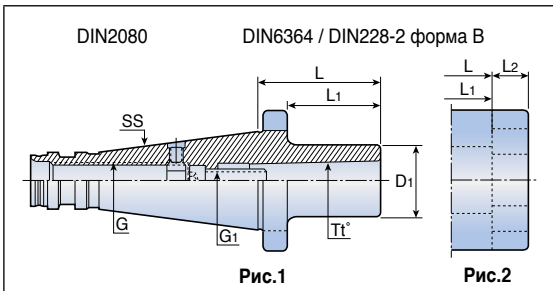
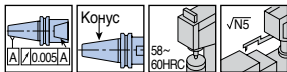

Обозначение	Размеры (мм)									Рис.
	SS	Tt°	D1	L	L1	L2	G1	G		
DIN2080 40	MT1 DRW	40	MT1	25	50	38.4	-	M6	M16	1
	MT2 DRW	40	MT2	32	50	38.4	-	M10	M16	1
	MT3 DRW	40	MT3	40	65	53.4	-	M12	M16	1
	MT4 DRW	40	MT4	63	110	-	15	M16	M16	2
DIN2080 50	MT1 DRW	50	MT1	25	60	44.8	-	M6	M24	1
	MT2 DRW	50	MT2	32	60	44.8	-	M10	M24	1
	MT3 DRW	50	MT3	40	65	49.8	-	M12	M24	1
	MT4 DRW	50	MT4	63	80	49.8	15	M16	M24	2
	MT5 DRW	50	MT5	78	100	84.4	18	M20	M24	2

• MT4 & MT5: DIN2201

DIN2080-DC

Оправка для сверлильных патронов

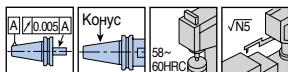
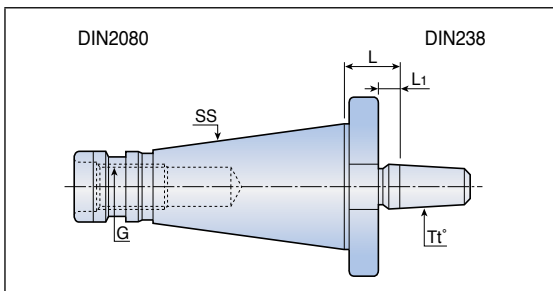

Обозначение	Размеры (мм)				
	SS	Tt°	L	L1	G
DIN2080 30 DC B16x20	30	B16	20	5.4	M12
DIN2080 40 DC B16x22	40	B16	22	10.4	M16
DC B18x25	40	B18	25	13.4	M16
DIN2080 50 DC B16x25	50	B16	25	9.8	M24
DC B18x25	50	B18	25	9.8	M24

DIN2080-CP

Центрирующая оправка

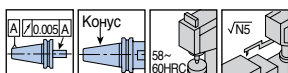
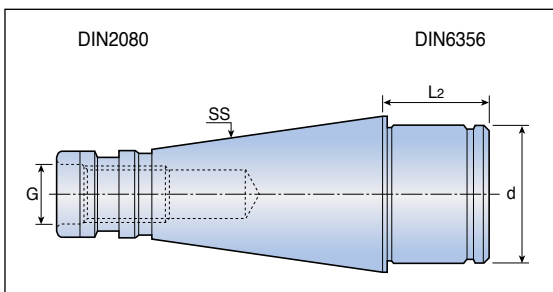

Обозначение	Размеры (мм)			
	SS	d	L2	G
DIN2080 40 CP 40	40	40	29	M16
DIN2080 50 CP 60	50	60	39	M24

C-ADAPTER



C-ADAPTER ISO 26623-1

Стандартный патрон

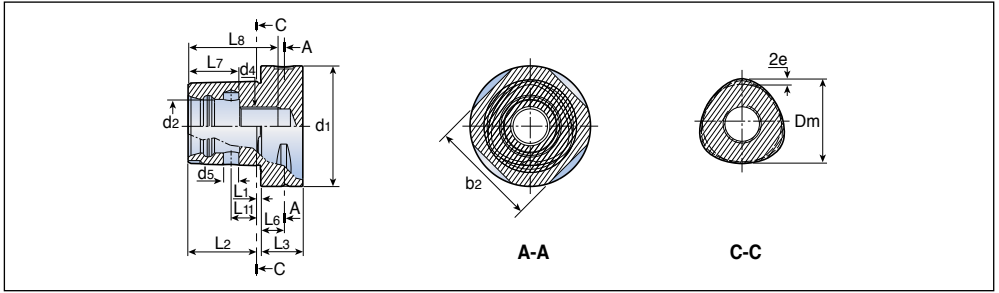

C-ADAPTER	b2	d1 ±0.1	d2	d4	d5 ±0.1	Dm	e
C3	28.3	32	15	M12x1.5	3.6	22	0.70
C4	35.3	40	18	M14x1.5	4.6	28	0.90
C5	44.4	50	21	M16x1.5	6.1	35	1.12
C6	55.8	63	28	M20x2	8.1	44	1.40
C8	71.1	80	32	M20x2	9.1	55	2.00

C-ADAPTER	L1	L2 ±0.1	L3 _{мин.}	L6 ±0.15	L7 ±0.15	L8 _{мин.}	L11 ±0.1
C3	2.5	19	15	6	13	25	8.0
C4	2.5	24	20	8	15	30	11.5
C5	3.0	30	20	10	20	37	14.0
C6	3.0	38	22	12	27	47	15.5
C8	3.0	48	30	12	28	48	25.0

* для нескладских позиций: Поставляется в случае наличия.
 Если нет на складе, применяется MOQ (Минимальное количество заказа).

C-ER

Цанговый патрон ER

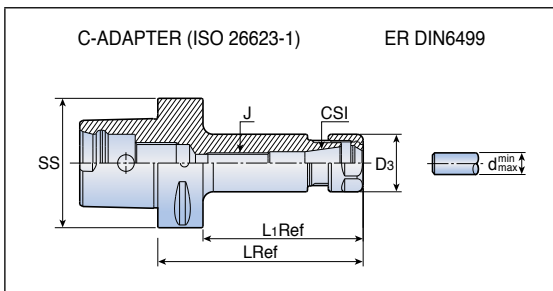
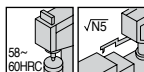

Обозначение	Размеры (мм)							
	SS	CSI	d _{мин.}	d _{макс.}	D ₃	L	L ₁	J
C4 ER 16x70	40	ER16	1.0	10.0	28	70	50	M10
ER 20x35 ⁽¹⁾	40	ER20	1.0	13.0	34	35	27	-
ER 20x52	40	ER20	1.0	13.0	34	52	32	-
ER 25x38 ⁽¹⁾	40	ER25	1.0	16.0	42	38	30	-
ER 25x52	40	ER25	1.0	16.0	42	52	32	-
ER 32x54	40	ER32	2.0	20.0	50	54	34	-
C5 ER 16x100	50	ER16	1.0	10.0	28	100	80	M10
ER 16x130	50	ER16	1.0	10.0	28	130	110	M10
ER 20x055	50	ER20	1.0	13.0	34	55	35	-
ER 20x100	50	ER20	1.0	13.0	34	100	80	M12
ER 20x130	50	ER20	1.0	13.0	34	130	110	M12
ER 25x055	50	ER25	1.0	16.0	42	55	35	-
ER 25x100	50	ER25	1.0	16.0	42	100	80	M16
ER 32x057	50	ER32	2.0	20.0	50	57	36	-
ER 32x100	50	ER32	2.0	20.0	50	100	80	M22x1.5
C6 ER 16x100	63	ER16	1.0	10.0	28	100	78	M10
ER 16x130	63	ER16	1.0	10.0	28	130	108	M10
ER 16x160	63	ER16	1.0	10.0	28	160	138	M10
ER 20x060	63	ER20	1.0	13.0	34	60	38	-
ER 20x100	63	ER20	1.0	13.0	34	100	78	M12
ER 20x130	63	ER20	1.0	13.0	34	130	108	M12
ER 20x160	63	ER20	1.0	13.0	34	160	138	M12
ER 25x060	63	ER25	1.0	16.0	42	60	38	-
ER 25x100	63	ER25	1.0	16.0	42	100	78	M16
ER 25x130	63	ER25	1.0	16.0	42	130	108	M16
ER 25x160	63	ER25	1.0	16.0	42	160	138	M16
ER 32x060	63	ER32	2.0	20.0	50	60	36	-
ER 32x100	63	ER32	2.0	20.0	50	100	78	M22x1.5
ER 32x130	63	ER32	2.0	20.0	50	130	108	M22x1.5
ER 32x160	63	ER32	2.0	20.0	50	160	138	M22x1.5
ER 40x065	63	ER40	3.0	26.0	63	65	37	-
ER 40x100	63	ER40	3.0	26.0	63	100	78	M28x1.5
ER 40x130	63	ER40	3.0	26.0	63	130	108	M28x1.5

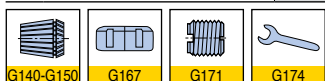

•⁽¹⁾ Без V-образных пазов, только для ручного использования

C-ER

Цанговый патрон ER

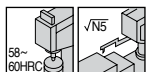
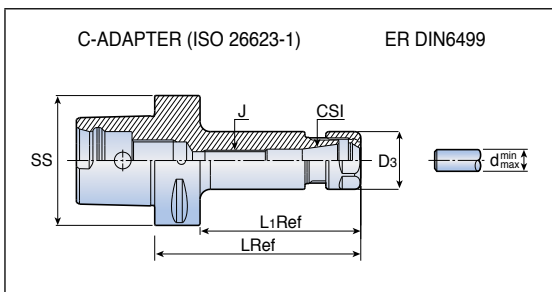

Обозначение	Размеры (мм)							
	SS	CSI	d _{мин.}	d _{макс.}	D ₃	L	L ₁	J
C8 ER 32x70	80	ER32	2.0	20.0	50	70	40	-
ER 32x100	80	ER32	2.0	20.0	50	100	70	M22x1.5
ER 32x160	80	ER32	2.0	20.0	50	160	130	M22x1.5
ER 40x70	80	ER40	3.0	26.0	63	70	40	-
ER 40x100	80	ER40	3.0	26.0	63	100	70	M28x1.5
ER 40x160	80	ER40	3.0	26.0	63	160	130	M28x1.5

C-ER-M

Цанговый патрон ER тип MINI

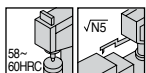
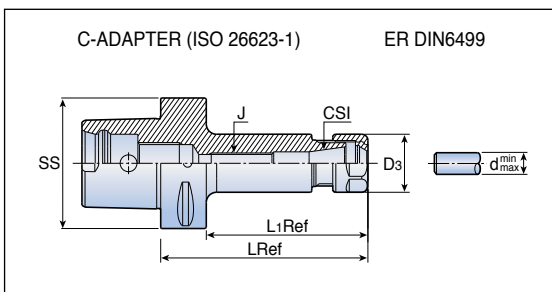

Обозначение	Размеры (мм)							
	SS	CSI	d _{мин.}	d _{макс.}	D ₃	L	L ₁	J
C4 ER 16x70 M	40	ER16	0.5	10.0	22	70	50	M10
C5 ER 16x100 M	50	ER16	0.5	10.0	22	100	80	M10
ER 16x130 M	50	ER16	0.5	10.0	22	130	120	M10
C6 ER 16x100 M	63	ER16	0.5	10.0	22	100	78	M10
ER 16x130 M	63	ER16	0.5	10.0	22	130	108	M10
ER 16x160 M	63	ER16	0.5	10.0	22	160	138	M10

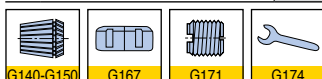

C-EM

Патрон для концевых фрез

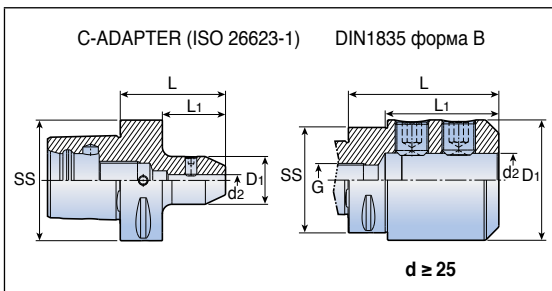
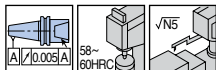

Обозначение	Размеры (мм)					
	SS	d2	D1	L	L1	G
C4 EM 6x50	40	6	25	50	30	M14
EM 8x50	40	8	28	50	30	M14
EM 10x50	40	10	35	50	30	M14
EM 12x55	40	12	42	55	35	M14
EM 14x55	40	14	44	55	35	M14
EM 16x60	40	16	48	60	40	M14
C5 EM 6x50	50	6	25	50	30	M16
EM 8x50	50	8	28	50	30	M16
EM 10x55	50	10	35	55	35	M16
EM 12x60	50	12	42	60	40	M16
EM 14x60	50	14	44	60	40	M16
EM 16x60	50	16	48	60	40	M16
EM 18x60	50	18	50	60	40	M16
EM 20x60	50	20	52	60	40	M16
EM 25x85	50	25	65	85	65	M16
C6 EM 6x55	63	6	25	55	33	M20
EM 8x55	63	8	28	55	33	M20
EM 10x60	63	10	35	60	38	M20
EM 12x60	63	12	42	60	38	M20
EM 14x60	63	14	44	60	38	M20
EM 16x65	63	16	48	65	43	M20
EM 18x65	63	18	50	65	43	M20
EM 20x65	63	20	52	65	43	M20
EM 25x80	63	25	65	80	58	M20
EM 32x90	63	32	72	90	68	M20
EM 40x100	63	40	90	100	78	M20



C-EM

Патрон для концевых фрез

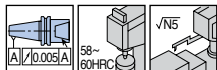
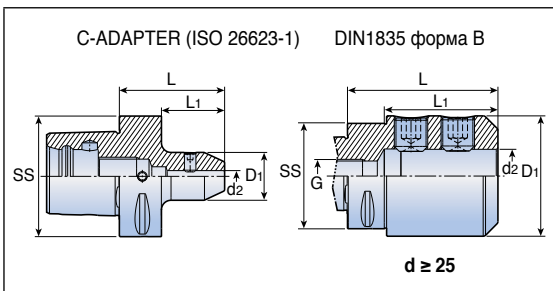

Обозначение	Размеры (мм)					
	SS	d2	D1	L	L1	G
C8 EM 6x70	80	6	25	70	40	M20
EM 8x70	80	8	28	70	40	M20
EM 10x70	80	10	35	70	40	M20
EM 12x70	80	12	42	70	40	M20
EM 14x70	80	14	44	70	40	M20
EM 16x70	80	16	48	70	40	M20
EM 18x70	80	18	50	70	40	M20
EM 20x70	80	20	52	70	40	M20
EM 25x90	80	25	65	90	60	M20
EM 32x95	80	32	72	95	65	M20
EM 40x110	80	40	90	110	80	M20
EM 50x120	80	50	98	120	90	M20



C-EM-E

Патрон для концевых фрез - тип Whistle notch

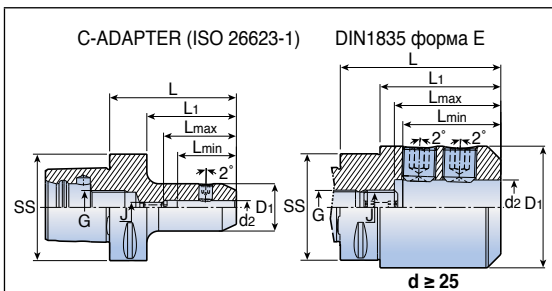
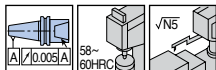

Обозначение	Размеры (мм)								
	SS	d2	D1	L	L _{мин.}	L _{макс.}	L1	G	J
C4 EM 6x70 E	40	6	25	70	30	35	50	M14	M5
EM 8x70 E	40	8	28	70	35	43	50	M14	M6
EM 10x70 E	40	10	35	70	39	45	50	M14	M8
EM 12x75 E	40	12	42	75	44	49	55	M14	M10
EM 14x75 E	40	14	44	75	44	49	55	M14	M10
EM 6x70 E	40	6	25	70	30	35	50	M16	M5
C5 EM 8x70 E	50	8	28	70	35	43	50	M16	M6
EM 10x70 E	50	10	35	70	39	45	50	M16	M8
EM 12x75 E	50	12	42	75	44	49	55	M16	M10
EM 14x75 E	50	14	44	75	44	49	55	M16	M10
EM 16x80 E	50	16	48	80	47	52	60	M16	M12
EM 18x80 E	50	18	50	80	47	52	60	M16	M12
EM 20x85 E	50	20	52	85	49	55	65	M16	M16
C6 EM 6x75 E	63	6	25	75	30	36	53	M20	M5
EM 8x75 E	63	8	28	75	35	43	53	M20	M6
EM 10x75 E	63	10	35	75	39	46	53	M20	M8
EM 12x80 E	63	12	42	80	44	49	58	M20	M10
EM 14x80 E	63	14	44	80	44	49	58	M20	M10
EM 16x85 E	63	16	48	85	47	52	63	M20	M12
EM 18x85 E	63	18	50	85	47	52	63	M20	M12
EM 20x85 E	63	20	52	85	49	55	63	M20	M16
EM 25x90 E	63	25	65	90	54	60	68	M20	M20
EM 32x95 E	63	32	72	95	58	63	73	M20	M20
C8 EM 6x65 E	80	6	25	65	30	36	35	M20	M5
EM 8x65 E	80	8	28	65	35	43	35	M20	M6
EM 10x65 E	80	10	35	65	39	46	35	M20	M8
EM 12x70 E	80	12	42	70	44	49	40	M20	M10
EM 14x70 E	80	14	44	70	44	49	40	M20	M10
EM 16x75 E	80	16	48	75	47	52	45	M20	M12
EM 18x75 E	80	18	50	75	47	52	45	M20	M12
EM 20x80 E	80	20	52	80	49	57	50	M20	M16
EM 25x90 E	80	25	65	90	54	60	60	M20	M20
EM 32x95 E	80	32	72	95	58	64	65	M20	M20



G171

C-SEM-C

Оправка для торцевых фрез

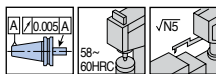
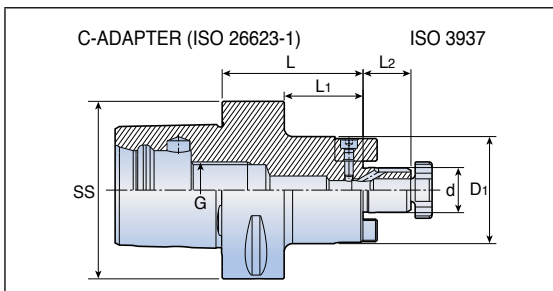

Обозначение	Размеры (мм)						
	SS	d	D1	L	L1	L2	G
C4 SEM 16x32 C	40	16	38	32	12	17	M14
SEM 16x55 C	40	16	38	55	35	17	M14
SEM 22x40 C	40	22	47	40	20	19	M14
SEM 22x55 C	40	22	47	55	35	19	M14
C5 SEM 16x35 C	50	16	38	35	15	17	M16
SEM 16x70 C	50	16	38	70	50	17	M16
SEM 22x35 C	50	22	47	35	15	19	M16
SEM 22x70 C	50	22	47	70	50	19	M16
SEM 27x40 C	50	27	58	40	20	21	M16
SEM 32x40 C	50	32	63	40	20	24	M16
C6 SEM 16x50 C	63	16	38	50	28	17	M20
SEM 16x100 C	63	16	38	100	78	17	M20
SEM 22x50 C	63	22	47	50	28	19	M20
SEM 22x100 C	63	22	47	100	78	19	M20
SEM 27x60 C	63	27	58	60	38	21	M20
SEM 27x100 C	63	27	58	100	78	21	M20
SEM 32x60 C	63	32	66	60	38	24	M20
SEM 40x60 C	63	40	82	60	38	27	M20
C8 SEM 16x50 C	80	16	38	50	20	17	M20
SEM 16x100 C	80	16	38	100	70	17	M20
SEM 22x50 C	80	22	47	50	20	19	M20
SEM 22x100 C	80	22	47	100	70	19	M20
SEM 27x50 C	80	27	58	50	20	21	M20
SEM 27x100 C	80	27	58	100	70	21	M20
SEM 32x50 C	80	32	66	50	20	24	M20
SEM 32x100 C	80	32	66	100	70	24	M20
SEM 40x60 C	80	40	82	60	30	27	M20

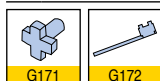

C-SEMC

Комбинированная оправка для торцевых/насадных фрез

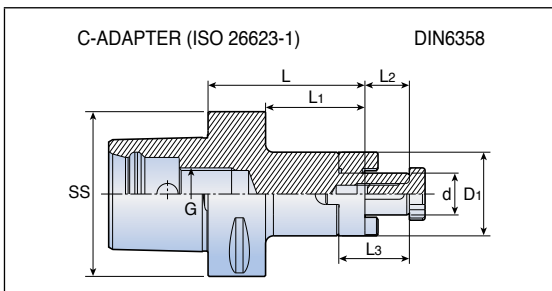
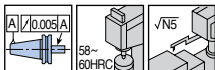

Обозначение	Размеры (мм)							
	SS	d	D1	L	L1	L2	L3	G
C4 SEMC 16x45	40	16	32	45	25	17	27	M14
SEMC 22x45	40	22	40	45	25	19	31	M14
SEMC 27x50	40	27	48	50	30	21	33	M14
C5 SEMC 16x55	50	16	32	55	35	17	27	M16
SEMC 16x85	50	16	32	85	65	17	27	M16
SEMC 22x65	50	22	40	65	45	19	31	M16
SEMC 27x85	50	27	48	85	65	21	33	M16
C6 SEMC 16x60	63	16	32	60	38	17	27	M20
SEMC 16x100	63	16	32	100	78	17	27	M20
SEMC 22x60	63	22	40	60	38	19	31	M20
SEMC 22x100	63	22	40	100	78	19	31	M20
SEMC 27x60	63	27	48	60	38	21	33	M20
SEMC 27x100	63	27	48	100	78	21	33	M20
SEMC 32x60	63	32	58	60	38	24	38	M20
SEMC 40x70	63	40	70	70	48	27	41	M20



Термо патрон для твердосплавных и стальных хвостовиков

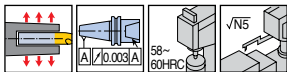
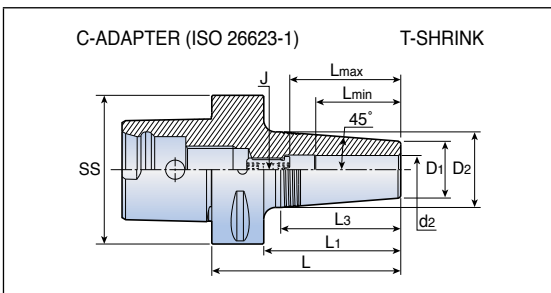

Обозначение	Размеры (мм)										
	SS	d2	D1	D2	L	L _{мин.}	L _{макс.}	L ₁	L ₃	J	Шестигранник
C4 SRKIN 6x75	40	6	21	27	75	25	36	55	38.1	M5	2.5
SRKIN 8x75	40	8	21	27	75	25	36	55	38.1	M6	3.0
SRKIN 10x75	40	10	24	32	75	31	42	55	50.8	M8	4.0
SRKIN 12x75	40	12	24	32	75	36	47	55	50.8	M10	5.0
SRKIN 14x80	40	14	27	34	80	36	47	60	44.5	M10	5.0
SRKIN 16x80	40	16	27	34	80	39	50	60	44.5	M12	6.0
SRKIN 18x80	40	18	33	42	80	39	50	60	57.2	M12	6.0
SRKIN 20x85	40	20	33	42	85	41	52	65	57.2	M16	8.0
C5 SRKIN 6x75	50	6	21	27	75	25	36	55	38.1	M5	2.5
SRKIN 8x75	50	8	21	27	75	25	36	55	38.1	M6	3.0
SRKIN 10x75	50	10	24	32	75	31	42	55	50.8	M8	4.0
SRKIN 12x75	50	12	24	32	75	36	47	55	50.8	M10	5.0
SRKIN 14x80	50	14	27	34	80	36	47	60	44.5	M10	5.0
SRKIN 16x80	50	16	27	34	80	39	50	60	44.5	M12	6.0
SRKIN 18x80	50	18	33	42	80	39	50	60	57.2	M12	6.0
SRKIN 20x85	50	20	33	42	85	41	52	65	57.2	M16	8.0
SRKIN 25x90	50	25	44	53	90	47	58	70	57.2	M16	8.0
C6 SRKIN 6x80	63	6	21	27	80	25	36	58	38.1	M5	2.5
SRKIN 8x80	63	8	21	27	80	25	36	58	38.1	M6	3.0
SRKIN 10x80	63	10	24	32	80	31	42	58	50.8	M8	4.0
SRKIN 12x80	63	12	24	32	80	36	47	58	50.8	M10	5.0
SRKIN 14x85	63	14	27	34	85	36	47	63	44.5	M10	5.0
SRKIN 16x85	63	16	27	34	85	39	50	63	44.5	M12	6.0
SRKIN 18x85	63	18	33	42	85	39	50	63	57.2	M12	6.0
SRKIN 20x85	63	20	33	42	85	41	52	63	57.2	M16	8.0
SRKIN 25x90	63	25	44	53	90	47	58	68	57.2	M16	8.0
SRKIN 32x95	63	32	44	53	95	47	58	73	57.2	M16	8.0



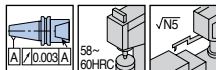
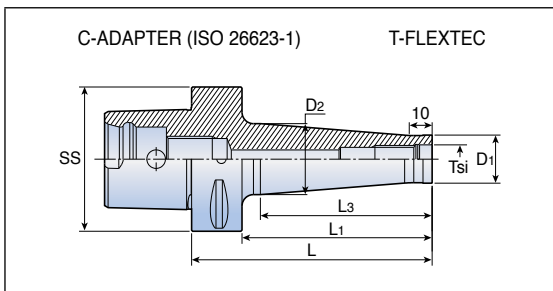

Обозначение	Размеры (мм)						
	SS	Tsi	D1	D2	L	L1	L3
C4 ODP 10x53	40	M10	18	23.0	53	33	23
ODP 12x53	40	M12	21	26.0	53	33	23
ODP 16x53	40	M16	29	34.0	53	33	23
C5 ODP 10x53	50	M10	18	19.5	53	33	25
ODP 10x103	50	M10	18	28.0	103	83	75
ODP 12x53	50	M12	21	23.5	53	33	25
ODP 12x103	50	M12	21	31.0	103	83	75
ODP 16x53	50	M16	29	29.5	53	33	25
ODP 16x103	50	M16	29	36.0	103	83	75
C6 ODP 10x55	63	M10	18	19.5	55	33	25
ODP 10x105	63	M10	18	28.0	105	83	75
ODP 10x130	63	M10	18	32.0	130	108	100
ODP 12x55	63	M12	21	23.5	55	33	25
ODP 12x105	63	M12	21	31.0	105	83	75
ODP 12x130	63	M12	21	36.0	130	108	100
ODP 16x55	63	M16	29	34.0	55	33	25
ODP 16x105	63	M16	29	34.0	105	83	75
ODP 16x130	63	M16	29	41.0	130	108	100

C-B4340

Заготовка

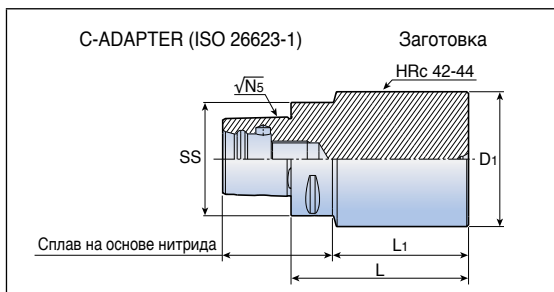

Обозначение	Размеры (мм)			
	SS	D ₁	L	L ₁
C4 B4340 040095	40	40	95	75
B4340 060165	40	60	165	144
B4340 080075	40	80	75	54
B4340 100085	40	100	85	64
C5 B4340 050125	50	50	125	105
B4340 075175	50	75	175	154
B4340 090080	50	90	80	59
B4340 110090	50	110	90	69
C6 B4340 075195	63	75	195	172
B4340 110085	63	110	85	62
B4340 130095	63	130	95	72
B4340 120180	63	120	180	157
C8 B4340 080200	80	80	200	170
B4340 120160	80	120	160	129
B4340 130090	80	130	90	59
B4340 145200	80	145	200	169

Цилиндрические, конические хвостовики и конус Морзе



ST-ER-M

Цанговый патрон ER MINI

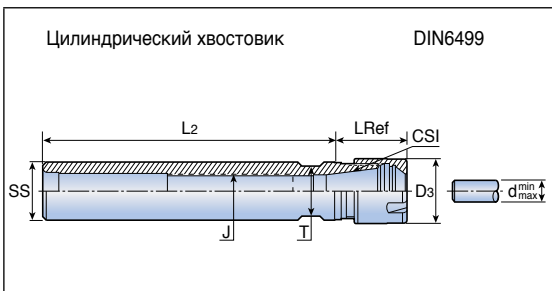
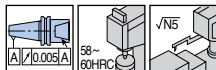

Обозначение	Размеры (мм)								
	SS	CSI	d _{мин.}	d _{макс.}	D ₃	L	L ₂	J	T
ST 12x80 ER11 M	12	ER11	0.5	7.0	16	26.5	80	-	11
16x100 ER11 M	16	ER11	0.5	7.0	16	18.5	100	M8	13
16x150 ER11 M	16	ER11	0.5	7.0	16	18.5	150	M8	13
12x80 ER16 M	12	ER16	0.5	10.0	22	36.5	80	-	17
20x100 ER16 M	20	ER16	0.5	10.0	22	25.0	100	M12	17
20x150 ER16 M	20	ER16	0.5	10.0	22	25.0	150	M12	17
20x100 ER20 M	20	ER20	1.0	13.0	28	40.0	100	M12	21
20x150 ER20 M	20	ER20	1.0	13.0	28	40.0	150	M12	21

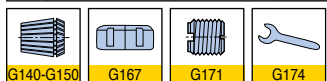

ST-ER-F

ER цанговый патрон

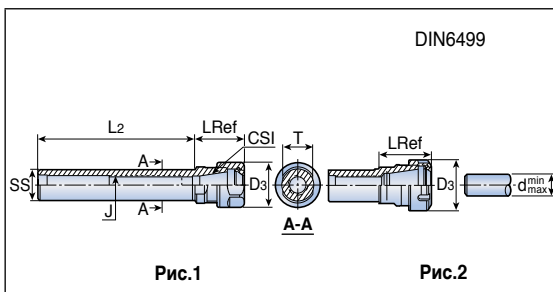
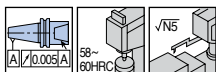

Обозначение	Размеры (мм)									Рис.
	SS	CSI	d _{мин.}	d _{макс.}	D ₃	L	L ₂	J	T	
ST 16x50 ER11 F	16	ER11	0.5	7.0	19	18.5	50	M8	13	1
20x50 ER11 F	20	ER11	0.5	7.0	19	18.5	50	M10	17	1
20x100 ER11	20	ER11	0.5	7.0	19	18.5	100	M10	17	1
20x100 ER11 F	20	ER11	0.5	7.0	19	18.5	100	M10	17	1
20x150 ER11	20	ER11	0.5	7.0	19	18.5	150	M10	17	1
20x50 ER16 F	20	ER16	0.5	10.0	28	32.3	50	M12	19	1
20x100 ER16	20	ER16	0.5	10.0	28	30.0	100	M12	19	1
20x100 ER16 F	20	ER16	0.5	10.0	28	30.0	100	M12	19	1
20x150 ER16	20	ER16	0.5	10.0	28	30.0	150	M12	19	1
20x50 ER20 F	20	ER20	1.0	13.0	34	42.5	50	M12	22	1
25x100 ER20	25	ER20	1.0	13.0	34	36.0	100	M16	22	1
25x150 ER20	25	ER20	1.0	13.0	34	36.0	150	M16	22	1
20x50 ER25 F	20	ER25	1.0	16.0	42	46.0	50	M12	28	2
20x100 ER25	20	ER25	1.0	16.0	42	46.0	100	M12	28	2
20x100 ER25 F	20	ER25	1.0	16.0	42	46.0	100	M12	28	2
25x50 ER25 F	25	ER25	1.0	16.0	42	46.0	50	M16	28	2
25x100 ER25	25	ER25	1.0	16.0	42	46.0	100	M16	28	2
20x50 ER32 F	20	ER32	2.0	20.0	50	54.0	50	M12	36	2
20x100 ER32	20	ER32	2.0	20.0	50	54.0	100	M12	36	2
20x100 ER32 F	20	ER32	2.0	20.0	50	54.0	100	M12	36	2
25x50 ER32 F	25	ER32	2.0	20.0	50	52.0	50	M16x2	36	2
30x50 ER32 F	30	ER32	2.0	20.0	50	52.0	50	M18x1.5	36	2
32x50 ER32 F	32	ER32	2.0	20.0	50	52.0	50	M18x1.5	36	2
32x150 ER32	32	ER32	2.0	20.0	50	52.0	150	M18x1.5	36	2
40x75 ER32 F	40	ER32	2.0	20.0	50	46.0	75	M22x1.5	44	2
25x50 ER40 F	25	ER40	3.0	26.0	63	60.0	50	M16x2	45	2
30x50 ER40 F	32	ER40	3.0	26.0	63	60.0	50	M18x1.5	45	2
32x50 ER40 F	32	ER40	3.0	26.0	63	60.0	50	M18x1.5	45	2
40x75 ER40 F	40	ER40	3.0	26.0	63	55.0	75	M22x1.5	45	2
50x80 ER40 F	50	ER40	3.0	26.0	63	60.0	80	M28x1.5	54	2
50x80 ER50 F	50	ER50	10.0	34.0	78	77.0	80	M36x1.5	58	2

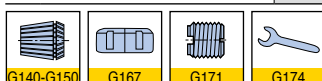

• F: Хвостовик с лыской

ST-ER-MF

Цилиндрический хвостовик - цанга MINI

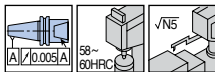
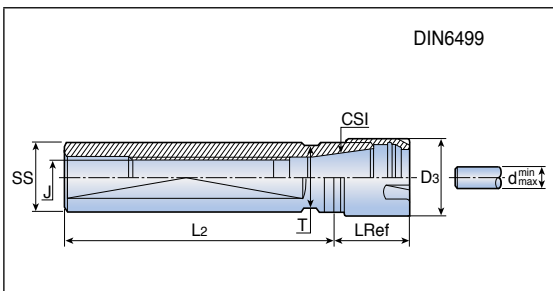

Обозначение	Размеры (мм)								
	SS	CSI	d _{мин.}	d _{макс.}	D ₃	L	L ₂	J	T
ST 16x38 ER11 MF	ER11	16	0.5	7.0	16	18.5	38	M8x1	14
16x50 ER11 MF	ER11	16	0.5	7.0	16	18.5	50	M8x1	13
16x140 ER11 MF	ER11	16	0.5	7.0	16	18.5	140	M8x1	14
16x35 ER16 MF	ER16	16	0.5	10.0	22	36.0	35	M8x1	17
20x50 ER16 MF	ER16	20	0.5	10.0	22	26.0	50	M12x1	17
20x70 ER16 MF	ER16	20	0.5	10.0	22	26.0	70	M12x1	17
20x120 ER16 MF	ER16	20	0.5	10.0	22	26.0	120	M12x1	17
20x140 ER16 MF	ER16	20	0.5	10.0	22	26.0	140	M12x1	17
22x38 ER16 MF	ER16	22	0.5	10.0	22	26.0	38	M12x1	19
22x70 ER16 MF	ER16	22	0.5	10.0	22	26.0	70	M12x1	19
22x100 ER16 MF	ER16	22	0.5	10.0	22	28.0	100	M12x1	19
25x65 ER16 MF	ER16	25	0.5	10.0	22	28.0	65	M14x1	22
22x80 ER20 MF	ER20	22	1.0	13.0	28	39.0	80	M12x1	21
25x100 ER20 MF	ER20	25	1.0	13.0	28	28.0	100	M14x1	22
25x154 ER20 MF	ER20	25	1.0	13.0	28	28.0	154	M14x1	22
22x70 ER25 MF	ER25	22	1.0	16.0	35	47.0	70	M12x1	27
25x75 ER25 MF	ER25	25	1.0	16.0	35	48.0	75	M14x1	27
25x145 ER25 MF	ER25	25	1.0	16.0	35	36.0	145	M14x1	27
32x70 ER25 MF	ER25	32	1.0	16.0	35	30.0	70	M18x1	27

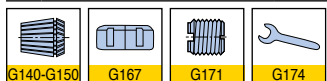

• MF: Хвостовик с лыской MINI

ST-ER-S

Цилиндрический хвостовик с подачей СОЖ

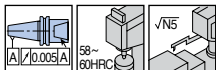
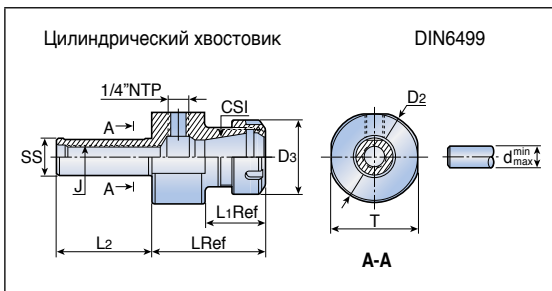

Обозначение	Размеры (мм)										
	SS	CSI	d _{мин.}	d _{макс.}	D ₂	D ₃	L	L ₁	L ₂	J	T
ST 20x65 ER16 S	20	ER16	0.5	10.0	40	28	54	29.6	65	M12	34
20x65 ER20 S	20	ER20	1.0	13.0	40	34	63	31.0	65	M12	34
20x65 ER25 S	20	ER25	1.0	16.0	54	42	72	32.0	65	M12	51
20x65 ER32 S	20	ER32	2.0	20.0	63	50	77	41.0	65	M12	59
25x65 ER25 S	25	ER25	1.0	16.0	54	42	72	32.0	65	M12	50
25x65 ER32 S	25	ER32	2.0	20.0	63	50	77	41.0	65	M16	59
32x65 ER32 S	32	ER32	2.0	20.0	63	50	77	41.0	65	M18x1.5	59
40x75 ER32 S	40	ER32	2.0	20.0	63	50	77	41.0	75	M22x1.5	59

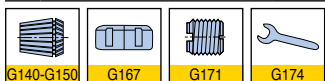

Твердосплавный хвостовик с подачей СОЖ T-FLEXTEC

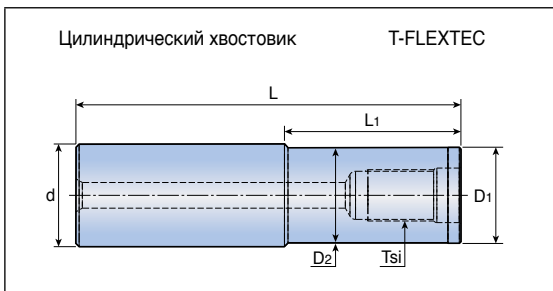
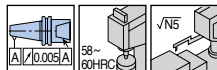

Обозначение	Размеры (мм)					
	Tsi	d	D1	D2	L	L1
S M08-CT16 - 20-L80	M8	16	15.3	15.3	80	20
40-L100	M8	16	15.3	15.3	100	40
80-L150	M8	16	15.3	15.3	150	80
100-L200	M8	16	13.0	12.5	200	100
140-L200	M8	16	13.0	12.5	200	140
180-L250	M8	16	13.0	12.5	250	180
S M10-CT20 - 20-L80	M10	20	18.0	17.5	80	20
40-L100	M10	20	18.0	17.5	100	40
80-L150	M10	20	18.5	18.5	150	80
100-L200	M10	20	18.0	17.5	200	100
140-L200	M10	20	18.0	17.5	200	140
130-L250	M10	20	18.0	17.5	250	130
180-L250	M10	20	18.0	17.5	250	180
180-L300	M10	20	18.0	17.5	300	180
230-L300	M10	20	18.0	17.5	300	230
S M12-CT25 - 40-L100	M12	25	21.0	20.5	100	40
80-L150	M12	25	21.0	20.5	150	80
100-L200	M12	25	21.0	20.5	200	100
140-L200	M12	25	21.0	20.5	200	140
130-L250	M12	25	21.0	20.5	250	130
180-L250	M12	25	21.0	20.5	250	180
180-L300	M12	25	21.0	20.5	300	180
230-L300	M12	25	21.0	20.5	300	230
S M16-CT32 - 40-L100	M16	32	29.0	28.0	100	40
80-L150	M16	32	29.0	28.0	150	80
100-L200	M16	32	29.0	28.0	200	100
140-L200	M16	32	29.0	28.0	200	140
130-L250	M16	32	29.0	28.0	250	130
180-L250	M16	32	29.0	28.0	250	180
180-L300	M16	32	29.0	28.0	300	180
230-L300	M16	32	29.0	28.0	300	230
230-L350	M16	32	29.0	28.0	350	230
280-L350	M16	32	29.0	28.0	350	280

• Все хвостовики с подачей СОЖ

Переходник

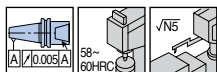
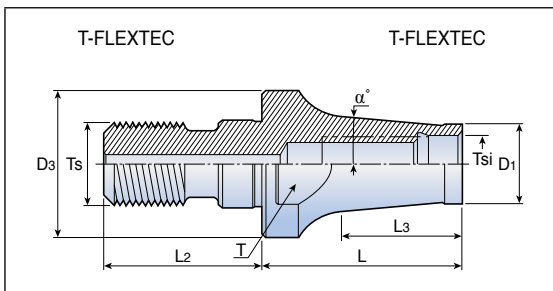

Обозначение	Размеры (мм)								
	Tsi	Ts	D1	D3	L	L2	L3	T	α°
CAB M06M08	M6	M8	9.7	13	30	17.5	24.8	9.5	5.7
M08M10	M8	M10	13.0	18	40	20.0	33.4	15.0	5.2
M10M12	M10	M12	18.0	21	45	22.0	36.4	17.0	2.5
M12M16	M12	M16	21.0	29	50	25.0	42.5	25.0	6.3

- С отверстиями СОЖ

CAB M-M-C

Удлинитель

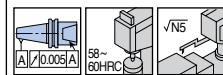
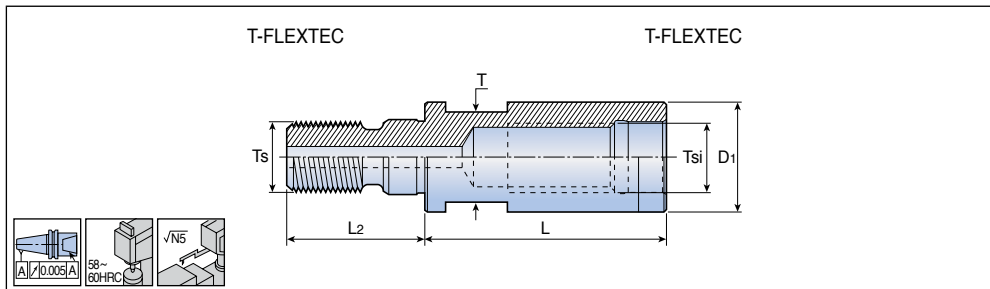

Обозначение	Размеры (мм)					
	Tsi	Ts	D1	L	L2	T
CAB M08M08-C	M8	M8	13	30	17.5	9.6
M10M10-C	M10	M10	18	35	20.0	15.0
M12M12-C	M12	M12	21	40	22.0	17.0
M16M16-C	M16	M16	29	40	25.0	25.0

- С отверстиями СОЖ

Переходник с SRK T-SHRINK

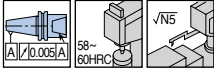
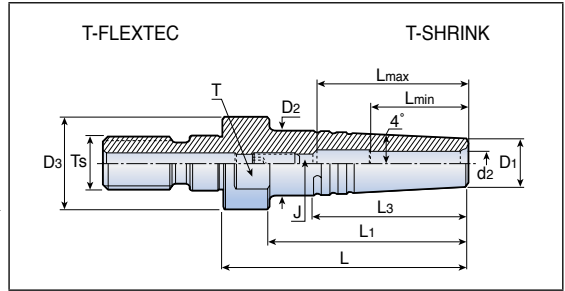

Обозначение	Размеры (мм)													
	Ts	d2	D1	D2	D3	L	L _{мин.}	L _{макс.}	L1	L3	J	T	Шестигранник	
CDP M10 SRK 3x40	M10	3	10	14	18	40	10	16	31.5	28.4	M4	15	2.0	
	SRK 4x40	M10	4	10	14	18	40	12	19	31.5	28.4	M4	15	2.0
	SRK 5x40	M10	5	10	14	18	40	15	25	31.5	28.4	M4	15	2.0
CDP M12 SRK 3x45	M12	3	10	14	21	45	10	16	36.5	28.8	M5	18	2.5	
	SRK 4x45	M12	4	10	14	21	45	12	18	36.5	28.8	M5	18	2.5
	SRK 5x45	M12	5	10	14	21	45	15	25	36.5	28.8	M5	18	2.5
	SRK 6x45	M12	6	11	15	21	45	18	28	36.5	28.4	M5	18	2.5
	SRK 8x45	M12	8	14	18	21	45	25	35	36.5	28.8	M5	18	2.5
	SRK 10x45	M12	10	16	21	21	45	30	40	-	35.6	M5	18	2.5
	SRK 12x45	M12	12	20	25	21	45	32	42	-	36.0	M5	18	2.5

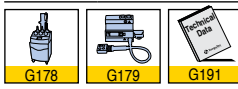

• С отверстиями СОЖ

CDP-ER-M

T-FLEXTEC

Переходник с цанговым патроном ER

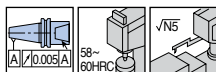
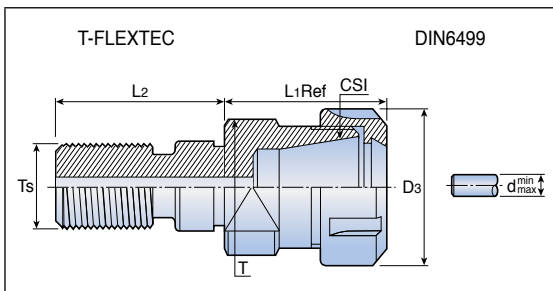

Обозначение	Размеры (мм)								
	CSI	Ts	d _{мин.}	d _{макс.}	D3	L1	L2	T	
CDP ER11 M10 M	ER11	M10	0.5	7.0	16	27.0	20	15	
ER11 M12 M	ER11	M12	0.5	7.0	16	27.0	22	17	
ER16 M10 M	ER16	M10	0.5	10.0	22	38.1	20	17	
ER16 M12 M	ER16	M12	0.5	10.0	22	37.1	22	17	
ER16 M16	ER16	M16	0.5	10.0	28	36.6	25	25	
ER20 M16	ER20	M16	1.0	13.0	34	45.5	25	25	
ER25 M16	ER25	M16	1.0	16.0	42	44.5	25	28	

• С отверстиями СОЖ

CAB M-SEM-C

T-FLEXTEC

Переходник под торцевые фрезы

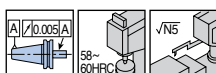
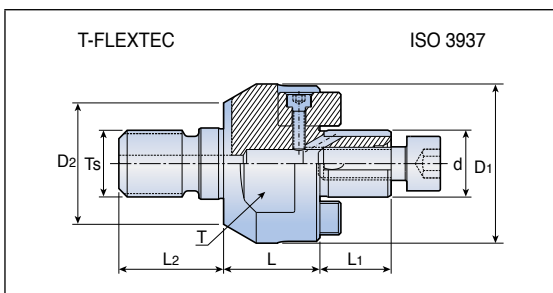

Обозначение	Размеры (мм)							
	Ts	d	D1	D2	L	L1	L2	T
CAB M16 SEM 16C	M16	16	38	29	23	17	2	30

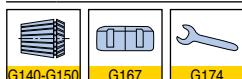

• С отверстиями СОЖ

GTI ER-ST

Патрон для метчика GTI

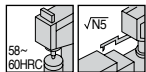
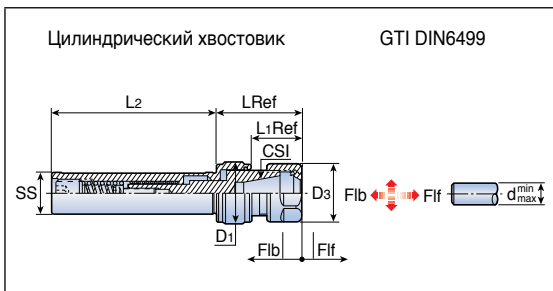

Обозначение	Размеры (мм)												
	SS	CSI	Тармин.	Тармакс.	d _{мин.}	d _{макс.}	D ₁	D ₃	L	L ₁	L ₂	Flf	Flb
GTI ER11 ST16x150 M	ST16	ER11	M2	M7	0.5	7.0	-	16	-	19.0	150	6	3
ER16 ST20x80	ST20	ER16	M3	M10	0.5	10.0	29.5	28	41.6	24.6	80	8	3
ER20 ST20x80	ST20	ER20	M4	M14	1.0	13.0	33.5	34	49.0	28.0	80	8	3
ER25 ST25x80	ST25	ER25	M5	M16	1.0	16.0	40.5	42	53.0	32.0	80	9	4
ER32 ST25x80	ST25	ER32	M6	M20	1.0	16.0	56.5	50	77.2	32.0	80	9	4
ER40 ST32x80	ST32	ER40	M6	M27	2.0	20.0	56.5	63	95.2	51.0	80	9	4

KIT GTI ER-ST

Патрон для метчика GTI

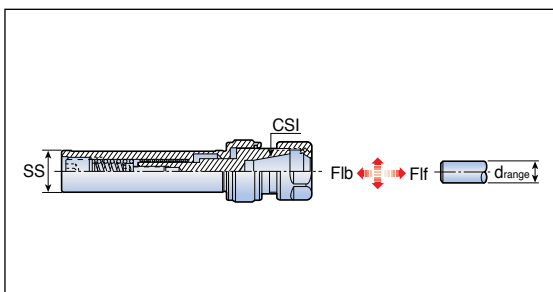

Обозначение	Размеры (мм)		
	SS	CSI	диапазон
KIT GTI ER11 ST16x150 4M	ST16	ER11	3, 4, 5, 6
ER16 ST20x80 4	ST20	ER16	4, 5, 6, 7
ER20 ST20x80 4	ST20	ER20	5, 6, 8, 9
ER25 ST25x80 5	ST25	ER25	6, 7, 9, 11, 12
ER32 ST25x80 6	ST25	ER32	6, 7, 9, 11, 12, 16
ER40 ST32x80 6	ST32	ER40	9, 11, 14, 16, 18, 20

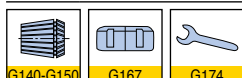

• GTI, цанга и ключ в комплекте

GFI ST-ER

GFI плавающий цанговый патрон ER

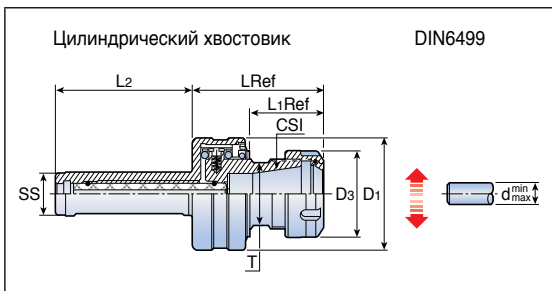
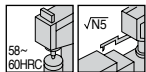

Обозначение	Размеры (мм)										
	SS	CSI	d _{мин.}	d _{макс.}	D ₁	D ₃	L	L ₁	L ₂	Радиальное смещение	T
GFI ST20 ER20	20	ER20	1.0	13.0	50	34	55.5	34.5	65	1.0	22
ST25 ER32	25	ER32	2.0	20.0	65	50	76.9	45.9	80	1.6	36

• Макс. 2,000 об./мин.

GFI MT-ER

Патрон для разверток с конусом Морзе

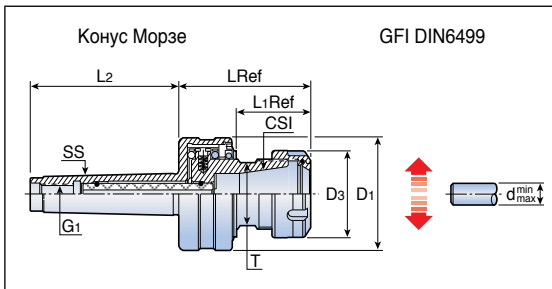
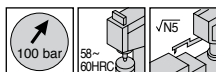

Обозначение	Размеры (мм)											
	SS	CSI	d _{мин.}	d _{макс.}	D ₁	D ₃	L	L ₁	L ₂	G ₁	Радиальное смещение	T
GFI MT2 ER20	2	ER20	1.0	13.0	50	34	60.5	34.5	64	M10	1.0	22
MT3 ER32	3	ER32	2.0	20.0	65	50	81.9	45.9	81	M12	1.6	36

• Макс. 2,000 об./мин.

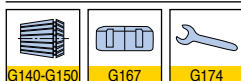

MT-ER

Цанговый патрон с конусом Морзе

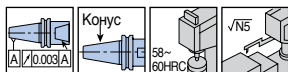
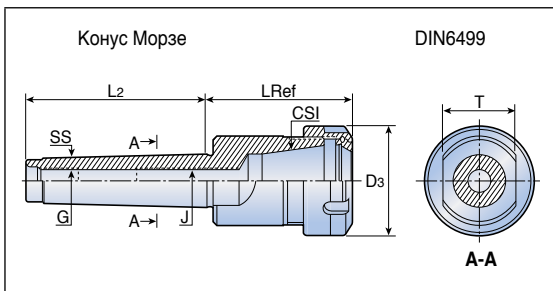

Обозначение	Размеры (мм)									
	SS	CSI	d _{мин.}	d _{макс.}	D ₃	L	L ₂	G	J	T
MT2 ER 20x48.5	2	ER20	1.0	13.0	34	48.5	64.0	M10	M10	22
ER 25x52	2	ER25	1.0	16.0	42	52.0	64.0	M10	M10	28
MT3 ER 32x69	3	ER32	2.0	20.0	50	69.0	81.0	M12	M12	24
ER 40x79	3	ER40	3.0	26.0	63	79.0	81.0	M12	M12	24
MT4 ER 32x61	4	ER32	2.0	20.0	50	60.5	102.5	M16	M16	32
ER 40x82	4	ER40	3.0	26.0	63	81.5	102.5	M16	M16	32
ER 50x108	4	ER50	10.0	34.0	78	107.5	102.5	M16	M16	32
MT5 ER 40x82	5	ER40	3.0	26.0	63	82.0	129.5	M20	M28x1.5	45
ER 50x85	5	ER50	10.0	34.0	78	85.0	129.5	M20	M28x1.5	45

MTA-TC

Патрон для метчиков MTA

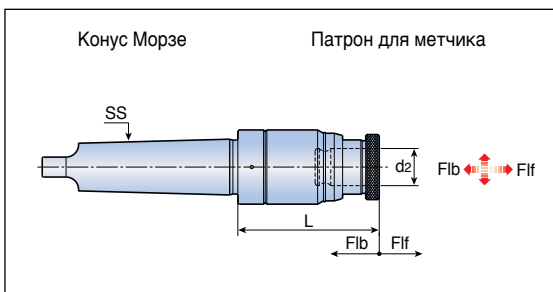

Обозначение	Размеры (мм)								Адаптер для метчиков
	SS	Тармин.	Тармакс.	d ₂	L	Flb	Flf		
MTA3 TC12-90	12	M3	M12	19	90	6.5	12	TA1	
TC22-115	22	M6	M24	31	115	14.5	13	TA2	
MTA4 TC12-105	12	M3	M12	19	105	6.5	12	TA1	
TC22-115	22	M6	M24	31	115	14.5	13	TA2	
MTA5 TC12-145	12	M3	M12	19	145	6.5	12	TA1	
TC22-175	22	M6	M24	31	175	14.5	13	TA2	

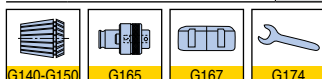

GYRO ST-ER

Цанговый патрон ER с системой центрирования GYRO

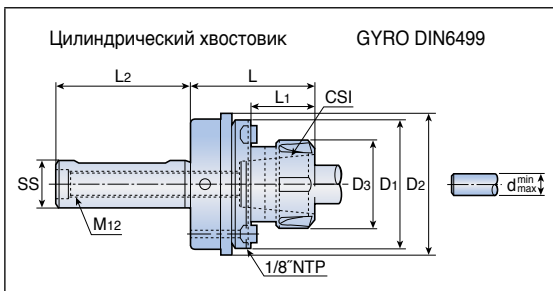
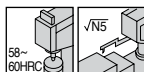

Обозначение	Размеры (мм)									
	SS	CSI	d _{мин.}	d _{макс.}	D1	D2	D3	L	L1	L2
GYRO ST20 ER20	20	ER20	1.0	13.0	57	63	34	58.80	28.5	80
ST25 ER25	25	ER25	1.0	16.0	74	79	42	65.65	35.5	80
ST25 ER32	25	ER32	2.0	20.0	74	79	50	66.65	36.5	80
ST32 ER32	32	ER32	2.0	20.0	74	79	50	66.65	36.5	80
ST40 ER32	40	ER32	2.0	20.0	74	79	50	66.65	36.5	80

• При первом использовании следует приобрести набор GYRO для балансировки

KIT GYRO ST-ER

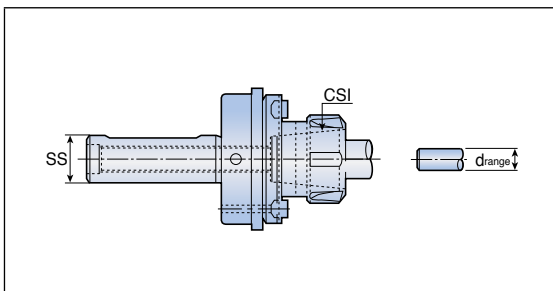

Обозначение	Размеры (мм)		
	SS	CSI	d _{диапазон}
KIT GYRO ST20 ER20	20	ER20	1-13
ST25 ER25	25	ER25	1-16
ST25 ER32	25	ER32	2-20
ST32 ER32	32	ER32	2-20
ST40 ER32	40	ER32	2-20

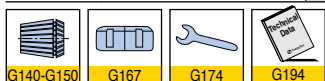

• Комплект включает: GYRO, тестовую оправку и втулку

GYRO DIN69880-ER

Цанговый патрон ER система центрирования GYRO

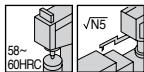
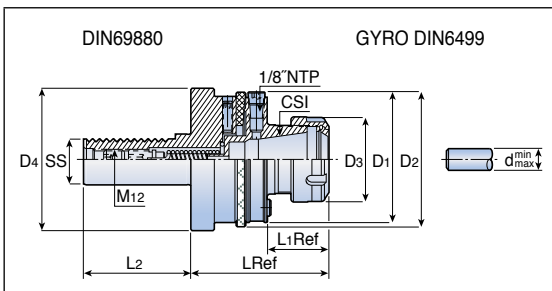

Обозначение	Размеры (мм)										
	SS	CSI	дмин.	дмакс.	D1	D2	D3	D4	L	L1	L2
GYRO DIN69880 30 ER32	VDI30	ER32	2.0	20.0	74	79	50	68.0	81.65	36.5	55
40 ER32	VDI40	ER32	2.0	20.0	74	79	50	83.2	81.65	36.5	63
50 ER32	VDI50	ER32	2.0	20.0	74	79	50	98.0	81.65	36.5	78

- При первом использовании следует приобрести набор GYRO для балансировки

KIT GYRO DIN69880-ER

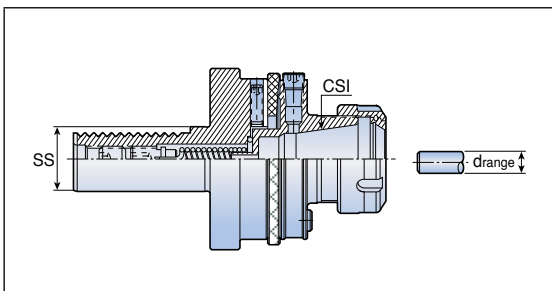

Обозначение	Размеры (мм)		
	SS	CSI	диапазон
KIT GYRO 40 DIN69880 ER32	VDI40	ER32	2-20
50 DIN69880 ER32	VDI50	ER32	2-20

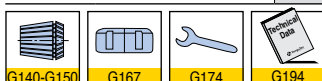

- Комплект включает: GYRO, тестовую оправку и втулку

TYPHOON



Компактный высокоскоростной шпиндель с хвостовиком HSK

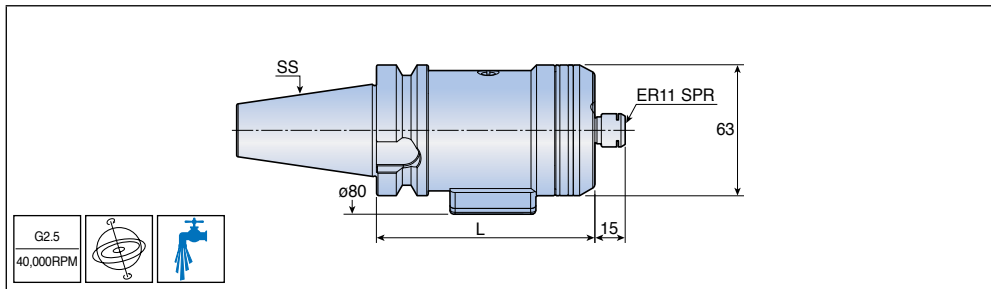

Обозначение	Размеры (мм)			
	SS	L	$d_{\text{макс.}}^{(1)}$	кг
TJS 20K BT30L	BT30	116	3.5	1.5
BT30R	BT30	116	3.5	1.5
BT40L	BT40	105	3.5	1.9
BT40R	BT40	105	3.5	1.9
TJS 30K BT30L	BT30	116	2.5	1.5
BT30R	BT30	116	2.5	1.5
BT40L	BT40	105	2.5	1.9
BT40R	BT40	105	2.5	1.9
TJS 40K BT30L	BT30	116	1.5	1.5
BT30R	BT30	116	1.5	1.5
BT40L	BT40	105	1.5	1.9
BT40R	BT40	105	1.5	1.9



- Максимальный диаметр хвостовика инструмента 6.0мм
- Минимальное давление СОЖ 20 бар и расход 12л/мин
- ⁽¹⁾ Макс. диаметр режущего инструмента

TJS-HSK A63

Компактный высокоскоростной шпиндель с хвостовиком HSK

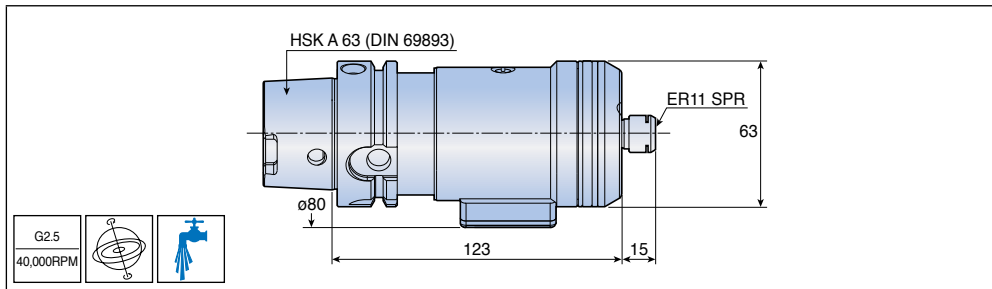

Обозначение	Размеры (мм)	
	$d_{\text{макс.}}^{(1)}$	кг
TJS 20K HSK A63L	3.5	1.6
HSK A63R	3.5	1.6
TJS 30K HSK A63L	2.5	1.6
HSK A63R	2.5	1.6
TJS 40K HSK A63L	1.5	1.6
HSK A63R	1.5	1.6



- Максимальный диаметр хвостовика инструмента 6.0мм
- Минимальное давление СОЖ 20 бар и расход 12л/мин
- ⁽¹⁾ Макс. диаметр режущего инструмента

Компактный высокоскоростной шпиндель с хвостовиком C-ADAPTER

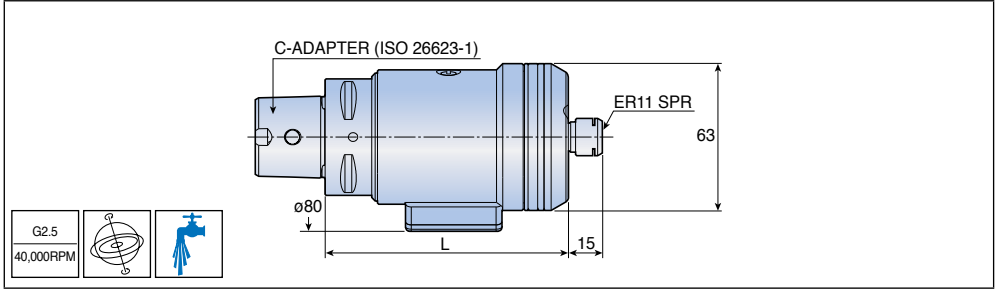

Обозначение	Размеры (мм)			
	SS	L	d _{макс.} ⁽¹⁾	кг
TJS 20K C5L	C5	104	3.5	1.50
C5R	C5	104	3.5	1.50
C6L	C6	106	3.5	1.65
C6R	C6	106	3.5	1.65
TJS 30K C5L	C5	104	2.5	1.50
C5R	C5	104	2.5	1.50
C6L	C6	106	2.5	1.65
C6R	C6	106	2.5	1.65
TJS 40K C5L	C5	104	1.5	1.50
C5R	C5	104	1.5	1.50
C6L	C6	106	1.5	1.65
C6R	C6	106	1.5	1.65



- Максимальный диаметр хвостовика инструмента 6.0мм
- Минимальное давление СОЖ 20 бар и расход 12л/мин
- ⁽¹⁾ Макс. диаметр режущего инструмента

Компактный высокоскоростной шпиндель с коническим хвостовиком CAT

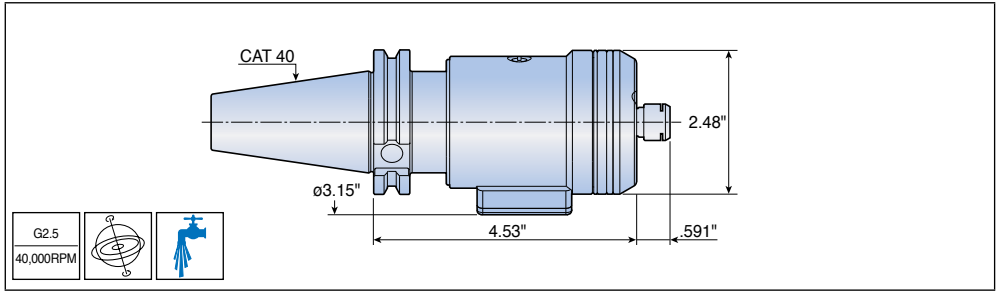

Обозначение	Размеры (мм)	
	д _{макс.} ⁽¹⁾	фунт
TJS 20K CAT40L	.138"	3.528
CAT40R	.138"	3.528
TJS 30K CAT40L	.100"	3.528
CAT40R	.100"	3.528
TJS 40K CAT40L	.060"	3.528
CAT40R	.060"	3.528



- Максимальный диаметр хвостовика инструмента .236"
- Минимальное давление СОЖ 290 фунт/кв. дюйм и расход 3.17 галл./мин
- ⁽¹⁾ Макс. диаметр режущего инструмента

Цанга



Цанга

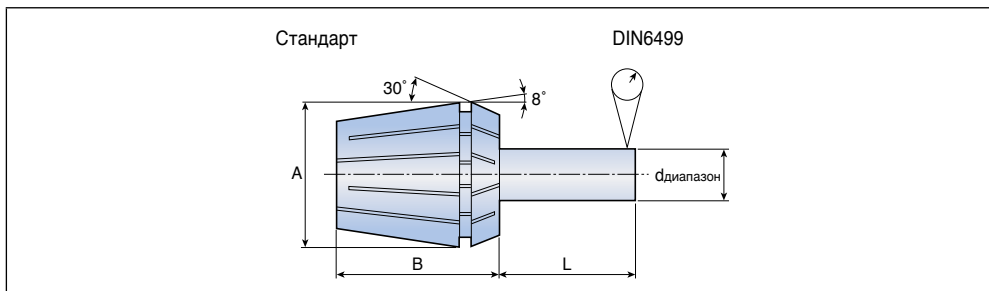

Точность

(мм)

Диаметр	L	Отклонение		
		Стандартная точность	Повышенная точность	DIN6499
1.0-1.6	6	0.01	0.005	-
1.6-3.0	10	0.01	0.005	0.015
3.0-6.0	16	0.01	0.005	0.015
6.0-10.0	25	0.01	0.005	0.015
10.0-18.0	40	0.01	0.005	0.020
18.0-26.0	50	0.01	0.005	0.020
26.0-34	60	-	-	0.025

Размеры

(мм)

Тип	A	B
ER11	11.5	18
ER16	17.0	27
ER20	21.0	31
ER25	26.0	35
ER32	33.0	40
ER40	41.0	46
ER50	52.0	60



G180-G182

ER-SPR

ER цанга

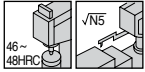
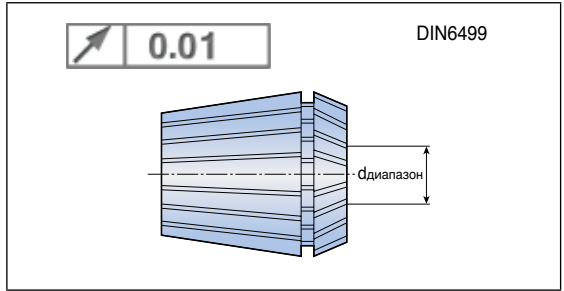

Диаметр	ER11	ER16	ER20	ER25	ER32	ER40	ER50
0.5-1	ER11 SPR 0.5-1	ER16 SPR 0.5-1					
1-2	1-2	1-2	ER20 SPR 1-2	ER25 SPR 1-2			
2-3	2-3	2-3	2-3	2-3	ER32 SPR 2-3		
3-4	3-4	3-4	3-4	3-4	3-4	ER40 SPR 3-4	
4-5	4-5	4-5	4-5	4-5	4-5	4-5	
5-6	5-6	5-6	5-6	5-6	5-6	5-6	
6-7	6-7	6-7	6-7	6-7	6-7	6-7	
7-8		7-8	7-8	7-8	7-8	7-8	
8-9		8-9	8-9	8-9	8-9	8-9	
9-10		9-10	9-10	9-10	9-10	9-10	
10-11			10-11	10-11	10-11	10-11	ER50 SPR 10-12
11-12			11-12	11-12	11-12	11-12	ER50 SPR 10-12
12-13			12-13	12-13	12-13	12-13	12-14
13-14				13-14	13-14	13-14	12-14
14-15				14-15	14-15	14-15	14-16
15-16				15-16	15-16	15-16	14-16
16-17					16-17	16-17	16-18
17-18					17-18	17-18	16-18
18-19					18-19	18-19	18-20
19-20					19-20	19-20	18-20
20-21						20-21	20-22
21-22						21-22	20-22
22-23						22-23	22-24
23-24						23-24	22-24
24-25						24-25	24-26
25-26						25-26	24-26
26-28							26-28
28-30							28-30
30-32							30-32
32-34							32-34

ER-SPR-AA

Высокоточная цапга ER

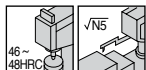
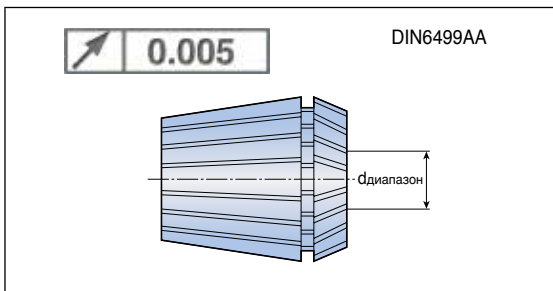

Диаметр	ER11	ER16	ER20	ER25	ER32	ER40
0.5-1	ER11 SPR 0.5-1AA	ER16 SPR 0.5-1AA				
1-2	1-2AA	1-2AA	ER20 SPR 1-2AA	ER25 SPR 1-2AA		
2-3	2-3AA	2-3AA	2-3AA	2-3AA	ER32 SPR 2-3AA	
3-4	3-4AA	3-4AA	3-4AA	3-4AA	3-4AA	ER40 SPR 3-4AA
4-5	4-5AA	4-5AA	4-5AA	4-5AA	4-5AA	4-5AA
5-6	5-6AA	5-6AA	5-6AA	5-6AA	5-6AA	5-6AA
6-7	6-7AA	6-7AA	6-7AA	6-7AA	6-7AA	6-7AA
7-8		7-8AA	7-8AA	7-8AA	7-8AA	7-8AA
8-9		8-9AA	8-9AA	8-9AA	8-9AA	8-9AA
9-10		9-10AA	9-10AA	9-10AA	9-10AA	9-10AA
10-11			10-11AA	10-11AA	10-11AA	10-11AA
11-12			11-12AA	11-12AA	11-12AA	11-12AA
12-13			12-13AA	12-13AA	12-13AA	12-13AA
13-14				13-14AA	13-14AA	13-14AA
14-15				14-15AA	14-15AA	14-15AA
15-16				15-16AA	15-16AA	15-16AA
16-17					16-17AA	16-17AA
17-18					17-18AA	17-18AA
18-19					18-19AA	18-19AA
19-20					19-20AA	19-20AA
20-21						20-21AA
21-22						21-22AA
22-23						22-23AA
23-24						23-24AA
24-25						24-25AA
25-26						25-26AA

EROH

Цанга ER с подачей СОЖ

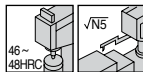
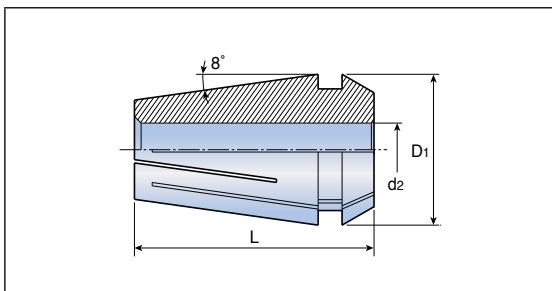

Обозначение	Размеры (мм)		
	d2диапазон	D1	L
EROH 16	4.0-10.0	17	27.5
EROH 20	6.0-13.0	21	31.5
EROH 25	6.0-16.0	26	34.0
EROH 32	8.0-20.0	33	40.0
EROH 40	10.0-26.0	41	46.0

d2диапазон	ER16	ER20	ER25	ER32	ER40
4	EROH 16-4				
5	EROH 16-5				
6	EROH 16-6	EROH 20-6	EROH 25-6		
7	EROH 16-7	EROH 20-7	EROH 25-7		
8	EROH 16-8	EROH 20-8	EROH 25-8	EROH 32-8	
9	EROH 16-9	EROH 20-9	EROH 25-9	EROH 32-9	
10	EROH 16-10	EROH 20-10	EROH 25-10	EROH 32-10	EROH 40-10
11		EROH 20-11	EROH 25-11	EROH 32-11	EROH 40-11
12		EROH 20-12	EROH 25-12	EROH 32-12	EROH 40-12
13		EROH 20-13	EROH 25-13	EROH 32-13	EROH 40-13
14			EROH 25-14	EROH 32-14	EROH 40-14
15			EROH 25-15	EROH 32-15	EROH 40-15
16			EROH 25-16	EROH 32-16	EROH 40-16
17				EROH 32-17	EROH 40-17
18				EROH 32-18	EROH 40-18
19				EROH 32-19	EROH 40-19
20				EROH 32-20	EROH 40-20
21					EROH 40-21
22					EROH 40-22
23					EROH 40-23
24					EROH 40-24
25					EROH 40-25
26					EROH 40-26

SET ER-SPR

Комплект цанг ER - стандартная точность TaeguTec

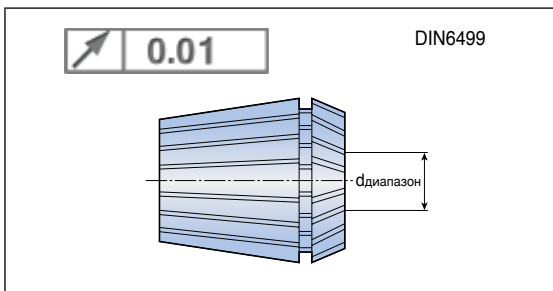
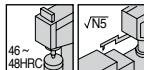

Обозначение	Количество / Набор	диапазон
SET ER11 SPR 7	7	0.5-7
ER16 SPR 10	10	0.5-10
ER20 SPR 12	12	1-13
ER25 SPR 15	15	1-16
ER32 SPR 18	18	2-20
ER40 SPR 23	23	3-26
ER50 SPR 12	12	10-34

SET ER-SPR-AA

Комплект цанг ER - повышенная точность TaeguTec "AA"

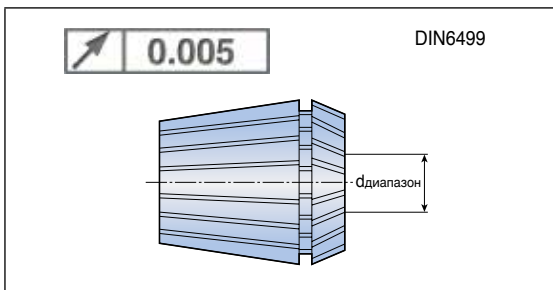
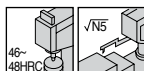

Обозначение	Количество / Набор	диапазон
SET ER11 SPR 7AA	7	0.5-7
ER16 SPR 10AA	10	0.5-10
ER20 SPR 12AA	12	1-13
ER25 SPR 15AA	15	1-16
ER32 SPR 18AA	18	2-20
ER40 SPR 23AA	23	3-26

SET ER-SEAL

ER COOLIT - Комплект цанг JET с подачей СОЖ

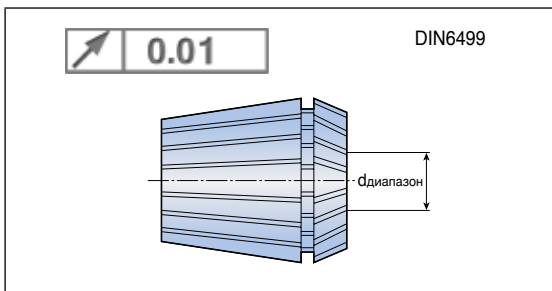
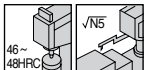

Обозначение	Количество / Набор	Диаметр
SET ER16 SEAL 7	7	3-10
ER20 SEAL 10	10	3-13
ER25 SEAL 13	13	3-16
ER32 SEAL 17	17	3-20
ER40 SEAL 23	23	3-26

SET ER-SEAL-JET2

ER COOLIT - Комплект цанг JET2 с подачей СОЖ

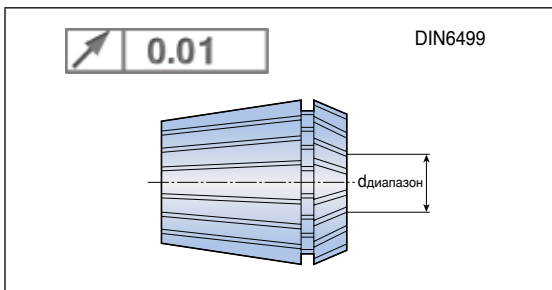
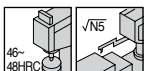

Обозначение	Количество / Набор	Диаметр
SET ER16 SEAL 7JET2	7	3-10
ER20 SEAL 10JET2	10	3-13
ER25 SEAL 13JET2	13	3-16
ER32 SEAL 17JET2	17	3-20
ER40 SEAL 23JET2	23	3-26

SET ER-SPR-EM

ER COOLIT - Стартовый комплект цанг - стандартная точность TaeguTec

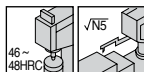

0.01

DIN6499

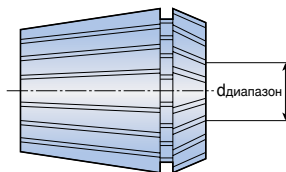

Обозначение	Количество / Набор	Диаметр
SET ER16 SPR 8 EM	8	3, 4, 5, 6, 7, 8, 9, 10
ER20 SPR 5 EM	5	4, 6, 8, 10, 12
ER25 SPR 6 EM	6	4, 6, 8, 10, 12, 16
ER32 SPR 6 EM	6	6, 8, 10, 12, 16, 20
ER40 SPR 7 EM	7	6, 8, 10, 12, 16, 20, 25

SET ER-SEAL-EM

ER COOLIT - Стартовый комплект герметичных цанг - стандартная точность TaeguTec

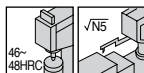

0.01

DIN6499

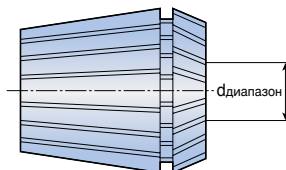

Обозначение	Количество / Набор	Диаметр
SET ER16 SEAL 5 EM	5	4, 5, 6, 8, 10
ER20 SEAL 5 EM	5	4, 6, 8, 10, 12
ER25 SEAL 6 EM	6	4, 6, 8, 10, 12, 16
ER32 SEAL 6 EM	6	6, 8, 10, 12, 16, 20
ER40 SEAL 7 EM	7	6, 8, 10, 12, 16, 20, 25

SET ER-SEAL-EM JET2

ER COOLIT - Начальный комплект цанг - стандартная точность TaeguTec

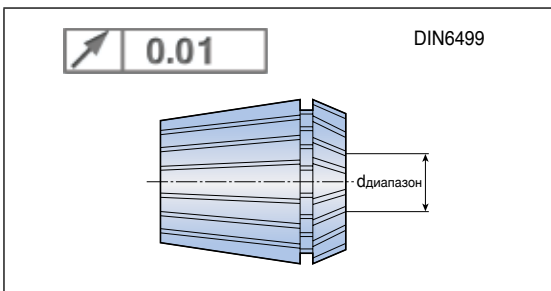
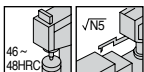

Обозначение	Количество / Набор	Диаметр
SET ER25 SEAL 6 EM JET2	6	4, 6, 8, 10, 12, 16
ER32 SEAL 6 EM JET2	6	6, 8, 10, 12, 16, 20
ER40 SEAL 7 EM JET2	7	6, 8, 10, 12, 16, 20, 25

KIT-ER

Комплект цанг ER - конический хвостовик

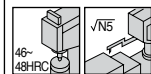

Обозначение	Количество / Набор	Диаметр
KIT DIN2080 30 18 ER32	18	2-20
DIN2080 40 18 ER32	18	2-20
DIN2080 40 23 ER40	23	3-26
DIN2080 50 23 ER40	23	3-26
MT3 18 ER32	18	2-20

- Каждый комплект содержит один цанговый патрон, полный набор цанг ER и ключ

KIT ST-ER M

Комплект цанг ER - Цилиндрический хвостовик



DIN6499

Обозначение	Количество / Набор	Диапазон
KIT ST 12x80 7 ER11 M	7	0.5-7
ST 16x50 7 ER11 MF	7	0.5-7
ST 16x100 7 ER11 M	7	0.5-7
ST 16x150 7 ER11 M	7	0.5-7
ST 12x80 10 ER16 M	10	0.5-10
ST 20x100 10 ER16 M	10	0.5-10
ST 20x150 10 ER16 M	10	0.5-10
ST 20x100 12 ER20 M	12	1-12
ST 20x150 12 ER20 M	12	1-12

• Каждый комплект содержит один цанговый патрон, полный набор цанг ER и ключ

KIT ST-ER

Комплект цанг ER - Цилиндрический хвостовик



DIN6499

Обозначение	Количество / Набор	Диапазон
KIT ST 16x50 7 ER11 F	7	0.5-7
ST 20x50 7 ER11 F	7	0.5-7
ST 20x100 7 ER11	7	0.5-7
ST 20x150 7 ER11	10	0.5-10
ST 20x50 10 ER16 F	10	0.5-10
ST 20x100 10 ER16	10	0.5-10
ST 20x150 10 ER16	12	1-12
ST 20x50 12 ER20 F	12	1-12

• Каждый комплект содержит один цанговый патрон, полный набор цанг ER и ключ

TSK

TSK цагга

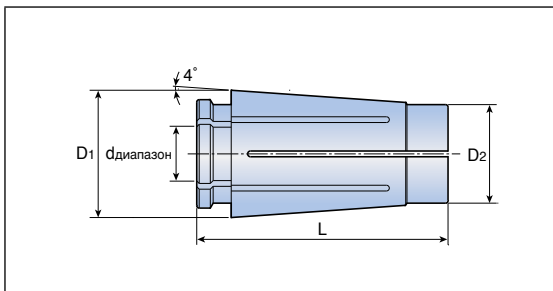

Обозначение	Размеры (мм)		
	D1	D2	L
TSK 06	10.4	7.5	25.0
TSK 10	15.5	12.0	30.6
TSK 16	24.6	18.8	45.0
TSK 25	35.7	28.8	57.0

диаметр	TSK 06	TSK 10	TSK 16	TSK 25
1.5-2.0	TSK 06-2.0	TSK 10-2.0		
2.0-2.5	TSK 06-2.5	TSK 10-2.5		
2.5-3.0	TSK 06-3.0	TSK 10-3.0	TSK 16-3.0	
3.0-3.5	TSK 06-3.5	TSK 10-3.5	TSK 16-3.5	
3.5-4.0	TSK 06-4.0	TSK 10-4.0	TSK 16-4.0	
4.0-4.5	TSK 06-4.5	TSK 10-4.5	TSK 16-4.5	
4.5-5.0	TSK 06-5.0	TSK 10-5.0	TSK 16-5.0	
5.0-5.5	TSK 06-5.5	TSK 10-5.5	TSK 16-5.5	
5.5-6.0	TSK 06-6.0	TSK 10-6.0	TSK 16-6.0	
6.0-6.5		TSK 10-6.5	TSK 16-6.5	
6.5-7.0		TSK 10-7.0	TSK 16-7.0	
7.0-7.5		TSK 10-7.5	TSK 16-7.5	
7.5-8.0		TSK 10-8.0	TSK 16-8.0	
8.0-8.5		TSK 10-8.5	TSK 16-8.5	
8.5-9.0		TSK 10-9.0	TSK 16-9.0	
9.0-9.5		TSK 10-9.5	TSK 16-9.5	
9.5-10.0		TSK 10-10.0	TSK 16-10.0	
10.0-10.5			TSK 16-10.5	
10.5-11.0			TSK 16-11.0	
11.0-11.5			TSK 16-11.5	
11.5-12.0			TSK 16-12.0	
12.0-12.5			TSK 16-12.5	
12.5-13.0			TSK 16-13.0	
13.0-13.5			TSK 16-13.5	
13.5-14.0			TSK 16-14.0	
14.0-14.5			TSK 16-14.5	
14.5-15.0			TSK 16-15.0	
15.0-15.5			TSK 16-15.5	
15.5-16.0			TSK 16-16.0	TSK 25-16.0
16.0-16.5				TSK 25-16.5
16.5-17.0				TSK 25-17.0

THC

Цилиндрическая цапга для гидравлического патрона

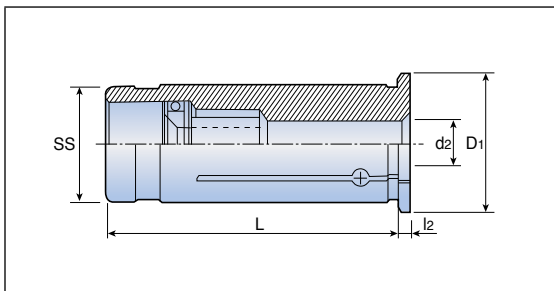

Обозначение	Размеры (мм)				
	SS	d2	D1	L	l2
THC 12-3	12	3	16	46.5	2
12-4	12	4	16	46.5	2
12-5	12	5	16	46.5	2
12-6	12	6	16	46.5	2
12-7	12	7	16	46.5	2
12-8	12	8	16	46.5	2
12-9	12	9	16	46.5	2
20-3	20	3	24	50.5	2
20-4	20	4	24	50.5	2
20-5	20	5	24	50.5	2
20-6	20	6	24	50.5	2
20-7	20	7	24	50.5	2
20-8	20	8	24	50.5	2
20-9	20	9	24	50.5	2
20-10	20	10	24	50.5	2
20-11	20	11	24	50.5	2
20-12	20	12	24	50.5	2
20-13	20	13	24	50.5	2
20-14	20	14	24	50.5	2
20-15	20	15	24	50.5	2
20-16	20	16	24	50.5	2
20-17	20	17	24	50.5	2
32-6	32	6	36	60.5	3
32-8	32	8	36	60.5	3
32-10	32	10	36	60.5	3
32-12	32	12	36	60.5	3
32-14	32	14	36	60.5	3
32-16	32	16	36	60.5	3
32-18	32	18	36	60.5	3
32-20	32	20	36	60.5	3
32-25	32	25	36	60.5	3

THC C

Цилиндрическая цапга с подачей СОЖ для гидравлического патрона

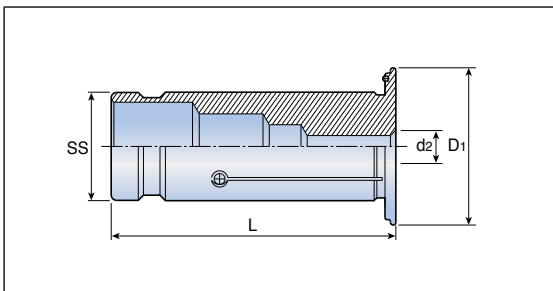

Обозначение	Размеры (мм)			
	SS	d2	D1	L
THC C12-3	12	3	19	47.0
C12-4	12	4	19	47.0
C12-5	12	5	19	47.0
C12-6	12	6	19	47.0
C12-7	12	7	19	47.0
C12-8	12	8	19	47.0
C20-3	20	3	29	52.5
C20-4	20	4	29	52.5
C20-5	20	5	29	52.5
C20-6	20	6	29	52.5
C20-7	20	7	29	52.5
C20-8	20	8	29	52.5
C20-9	20	9	29	52.5
C20-10	20	10	29	52.5
C20-11	20	11	29	52.5
C20-12	20	12	29	52.5
C20-13	20	13	29	52.5
C20-14	20	14	29	52.5
C20-15	20	15	29	52.5
C20-16	20	16	29	52.5
C20-17	20	17	29	52.5
C32-6	32	6	39	63.5
C32-8	32	8	39	63.5
C32-10	32	10	39	63.5
C32-12	32	12	39	63.5
C32-14	32	14	39	63.5
C32-16	32	16	39	63.5
C32-18	32	18	39	63.5
C32-20	32	20	39	63.5
C32-25	32	25	39	63.5

Цилиндрическая цапга для фрезерного патрона

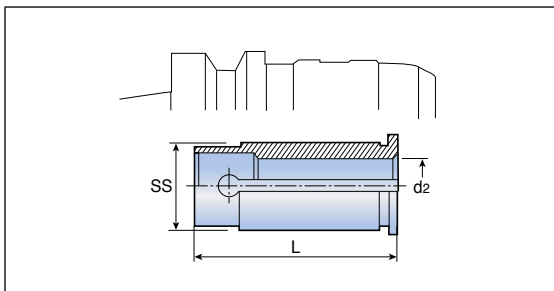

Обозначение	Размеры (мм)		
	SS	d2	L
CSR 20-4	20	4	50
20-6	20	6	50
20-8	20	8	50
20-10	20	10	50
20-12	20	12	50
20-16	20	16	50
25-4	25	4	60
25-6	25	6	60
25-8	25	8	60
25-10	25	10	60
25-12	25	12	60
25-16	25	16	60
25-20	25	20	60
32-4	32	4	65
32-6	32	6	65
32-8	32	8	65
32-10	32	10	65
32-12	32	12	65
32-16	32	16	65
32-20	32	20	65
32-25	32	25	65
42-4	42	4	75
42-6	42	6	75
42-8	42	8	75
42-10	42	10	75
42-12	42	12	75
42-16	42	16	75
42-20	42	20	75
42-25	42	25	75
42-32	42	32	75

CMR

Цанга для фрезерного патрона - Конус Морзе



CMR Тип

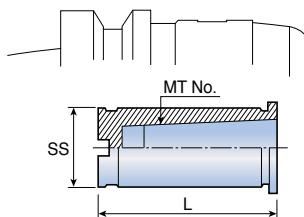

Обозначение	MT №	Размеры (мм)		Патрон
		SS	L	
CMR 32-1	1	32	58	TMC 32
32-2	2	32	71	TMC 32
32-3	3	32	89	TMC 32
42-1	1	42	58	TMC 42
42-2	2	42	71	TMC 42
42-3	3	42	89	TMC 42
42-4	4	42	111	TMC 42

CJA

Цанги для фрезерных патронов - Переходники с конусом Морзе



CJA Тип

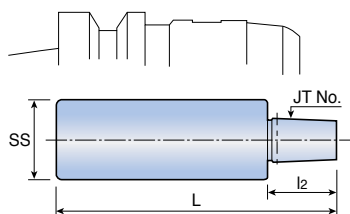

Обозначение	JT №	Размеры (мм)			Патрон
		SS	L	l ₂	
CJA 32-6	6	32	118	28	TMC 32
42-6	6	42	128	28	TMC 42

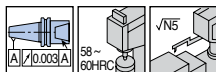
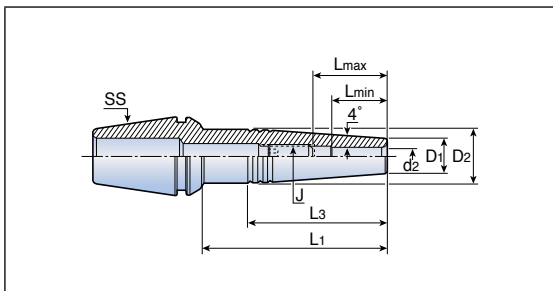

Обозначение	Размеры (мм)									
	SS	d2	D1	D2	L _{мин.}	L _{макс.}	L1	L3	J	Шестигранник
ER32 SRK 3x35	ER32	3	10	13.5	10	16	35	22.5	M6	3.0
SRK 3x60	ER32	3	10	16.3	10	16	60	44.5	M6	3.0
SRK 3x85	ER32	3	10	19.8	10	16	85	70.0	M6	3.0
SRK 4x35	ER32	4	10	13.5	12	18	35	23.5	M6	3.0
SRK 4x60	ER32	4	10	16.3	12	18	60	44.5	M6	3.0
SRK 4x85	ER32	4	10	19.8	12	18	85	70.0	M6	3.0
SRK 5x35	ER32	5	10	13.5	15	21	35	24.5	M6	3.0
SRK 5x60	ER32	5	10	16.3	15	21	60	44.5	M6	3.0
SRK 5x85	ER32	5	10	19.8	15	21	85	70.0	M6	3.0
SRK 6x35	ER32	6	11	14.7	18	24	35	25.5	M8	4.0
SRK 6x60	ER32	6	11	17.3	18	24	60	45.0	M8	4.0
SRK 6x85	ER32	6	11	20.8	18	26	85	69.5	M8	4.0
SRK 8x35	ER32	8	14	18.9	25	31	35	33.0	M10	5.0
SRK 8x60	ER32	8	14	20.4	25	31	60	45.0	M10	5.0
SRK 8x85	ER32	8	14	23.2	25	31	85	65.0	M10	5.0
SRK 10x35	ER32	10	16	20.8	30	35	35	34.0	M12	6.0
SRK 10x60	ER32	10	16	22.4	30	36	60	44.5	M12	6.0
SRK 10x85	ER32	10	16	23.0	30	36	85	49.5	M12	6.0
SRK 12x35	ER32	12	20	24.0	32	-	35	28.0	-	-
SRK 12x60	ER32	12	20	24.0	32	38	60	28.0	M14	6.0
SRK 12x85	ER32	12	20	24.0	32	38	85	28.0	M14	6.0

ER цагга

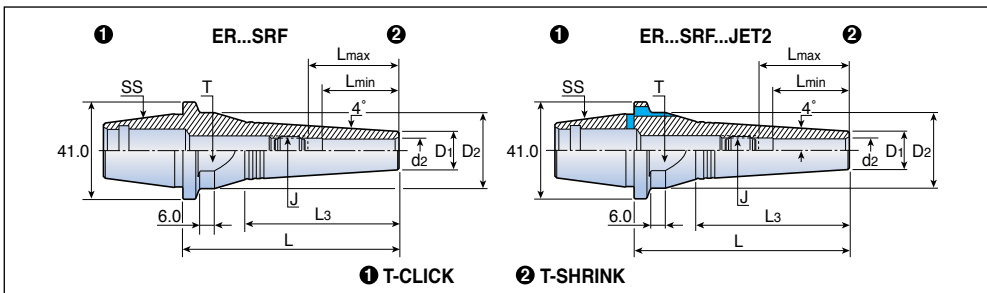

Обозначение	Размеры (мм)								
	SS	d	D1	D2	L	L _{мин.}	L _{макс.}	L3	J
ER32 SRF 3x50	32 SRF	3	10	32	50	10	16	31.0	M6
SRF 3x85	32 SRF	3	10	32	85	10	16	60.5	M6
SRF 4x50	32 SRF	4	10	32	50	12	18	31.0	M6
SRF 4x85	32 SRF	4	10	32	85	12	18	60.5	M6
SRF 5x50	32 SRF	5	10	32	50	15	21	31.0	M6
SRF 5x85	32 SRF	5	10	32	85	15	21	60.5	M6
SRF 6x50	32 SRF	6	11	32	50	18	24	31.0	M8
SRF 6x85	32 SRF	6	11	32	85	18	24	60.5	M8
SRF 8x50	32 SRF	8	14	32	50	25	31	33.0	M10
SRF 8x85	32 SRF	8	14	32	85	25	31	60.5	M10
SRF 10x50	32 SRF	10	16	32	50	30	35	35.0	M12
SRF 10x85	32 SRF	10	16	32	85	30	36	60.5	M12
SRF 12x50	32 SRF	12	20	32	50	32	37	35.0	M14
SRF 12x85	32 SRF	12	20	32	85	32	38	50.0	M14
ER32 SRF 3x50 JET2	32 SRF	3	10	32	50	10	16	31.0	M6
SRF 3x85 JET2	32 SRF	3	10	32	85	10	16	60.5	M6
SRF 4x50 JET2	32 SRF	4	10	32	50	12	18	31.0	M6
SRF 4x85 JET2	32 SRF	4	10	32	85	12	18	60.5	M6
SRF 5x85 JET2	32 SRF	5	10	32	85	15	21	60.5	M6
SRF 6x50 JET2	32 SRF	6	11	32	50	18	24	31.0	M8
SRF 6x85 JET2	32 SRF	6	11	32	85	18	24	60.5	M8
SRF 8x50 JET2	32 SRF	8	14	32	50	25	31	33.0	M10
SRF 8x85 JET2	32 SRF	8	14	32	85	25	31	60.5	M10
SRF 10x50 JET2	32 SRF	10	16	32	50	30	35	35.0	M12
SRF 10x85 JET2	32 SRF	10	16	32	85	30	36	60.5	M12
SRF 12x50 JET2	32 SRF	12	20	32	50	32	37	35.0	M14
SRF 12x85 JET2	32 SRF	12	20	32	85	32	38	50.0	M14

• Затяжное усилие: 24 кг х м / 24 кгс*м

GTIN ER

GTIN ER цанга

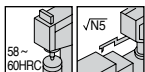
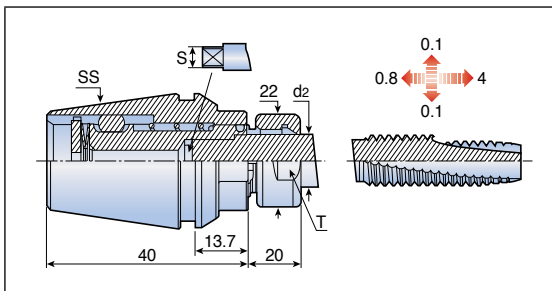

GTIN ER 32 - DIN 371 / 352

Обозначение	Размеры (мм)					
	SS	d2	Тармин.	Тармакс.	S	T
GTIN ER32 DIN 2.50x2.10	ER32	2.5	M1	M1.8	2.1	20
DIN 2.80x2.10	ER32	2.8	M2	M4	2.1	20
DIN 3.50x2.70	ER32	3.5	M3	M5	2.7	20
DIN 4.00x3.00	ER32	4.0	M3.5	M3.5	3.0	20
DIN 4.50x3.40	ER32	4.5	M4	M6	3.4	20
DIN 6.00x4.90	ER32	6.0	M5	M8	4.9	20
DIN 7.00x5.50	ER32	7.0	M7	M10	5.5	20
DIN 8.00x6.20	ER32	8.0	M8	M8	6.2	20
DIN 9.00x7.00	ER32	9.0	M12	M12	7.0	20
DIN 10.00x8.00	ER32	10.0	M10	M10	8.0	20
DIN 11.00x9.00	ER32	11.0	M14	M14	9.0	20
DIN 12.00x9.00	ER32	12.0	M16	M16	9.0	20

GTIN ER 32 - JIS

Обозначение	Размеры (мм)					
	SS	d2	Тармин.	Тармакс.	S	T
GTIN ER32 JIS 3.00x2.50	ER32	3.0	M1	M2.6	2.5	20
JIS 4.00x3.20	ER32	4.0	M3	M3.5	3.2	20
JIS 5.00x4.00	ER32	5.0	M4	M4	4.0	20
JIS 6.00x4.50	ER32	6.0	M6	M6	4.5	20
JIS 6.20x5.00	ER32	6.2	M8	M8	5.0	20
JIS 7.00x5.50	ER32	7.0	M10	M10	5.5	20
JIS 8.50x6.50	ER32	8.5	M12	M12	6.5	20
JIS 10.50x8.00	ER32	10.5	M14	M14	8.0	20
JIS 12.50x10.00	ER32	12.5	M16	M16	10.0	20

• Нельзя подавать СОЖ через патрон - это приведет к поломке.

ТА

Переходная втулка

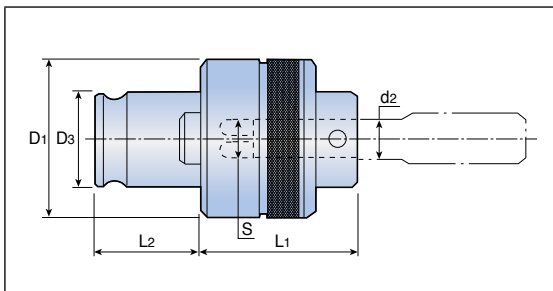

Обозначение	Размеры (мм)					
	d2	D1	D3	L1	L2	S
ТА 1-M3	4.0	32	19	25	21.5	3.2
1-M4	5.0	32	19	25	21.5	4.0
1-M5	5.5	32	19	25	21.5	4.5
1-M6	6.0	32	19	25	21.5	4.5
1-M8	6.2	32	19	25	21.5	5.0
1-M10	7.0	32	19	25	21.5	5.5
1-M12	8.5	32	19	25	21.5	6.5
2-M6	6.0	50	31	33	35.5	4.5
2-M8	6.2	50	31	33	35.5	5.0
2-M10	7.0	50	31	33	35.5	5.5
2-M12	8.5	50	31	33	35.5	6.5
2-M14	10.5	50	31	33	35.5	8.0
2-M16	12.5	50	31	33	35.5	10.0
2-M18	14.0	50	31	33	35.5	11.0
2-M20	15.0	50	31	33	35.5	12.0
2-M22	17.0	50	31	33	35.5	13.0
2-M24	19.0	50	31	33	35.5	15.0
3-M18	14.0	72	48	45	55.5	11.0
3-M20	15.0	72	48	45	55.5	12.0
3-M22	17.0	72	48	45	55.5	13.0
3-M24	19.0	72	48	45	55.5	15.0
3-M27	20.0	72	48	45	55.5	15.0
3-M30	23.0	72	48	45	55.5	17.0
3-M33	25.0	72	48	45	55.5	19.0
3-M36	28.0	72	48	45	55.5	19.0
3-M38	28.0	72	48	45	55.5	21.0

• На основе стандарта JIS

Комплектующие



NUT ER TOP

Зажимная гайка

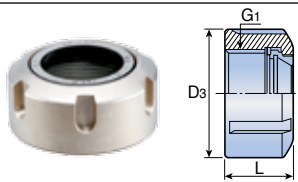

Обозначение	Размеры (мм)		
	D3	L	G1
NUT ER16 TOP	28	17	M22x1.5
ER20 TOP	34	19	M25x1.5
ER25 TOP	42	20	M32x1.5
ER32 TOP	50	22	M40x1.5
ER40 TOP	63	25	M50x1.5

NUT ER MINI/UM

Зажимная гайка

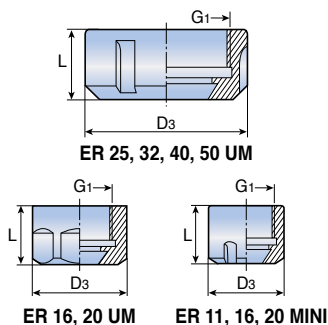

Обозначение	Размеры (мм)		
	D3	L	G1
NUT ER11 MINI	16	10.8	M13x0.75
ER11 UM	19	11.3	M14x0.75
ER16 MINI	22	18.0	M19x1.0
ER16 UM	28	17.0	M22x1.5
ER20 MINI	28	19.0	M24x1.0
ER20 UM	34	19.0	M25x1.5
ER25 MINI	35	20.0	M30x1.5
ER25 UM	42	20.0	M32x1.5
ER32 UM	50	22.0	M40x1.5
ER40 UM	63	25.0	M50x1.5
ER50 UM	78	55.0	M64x2.0

NUT ER11 GHS



Зажимная гайка

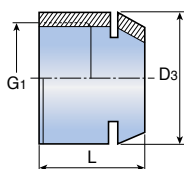

Обозначение	Размеры (мм)			
	G1	D3	L	Wrench
NUT ER11 GHS	M13x0.75	16	11.5	WRENCH ER11 SMS

NUT ER TOP BIN

Балансируемая зажимная гайка

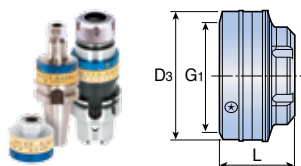

Обозначение	Размеры (мм)		
	D3	L	G1
NUT ER16 TOP BIN	44	36.0	M22x1.5
ER20 TOP BIN	50	37.0	M25x1.5
ER25 TOP BIN	58	37.5	M32x1.5

NUT ER SHORT

ГАЙКА T-SHORT

	Обозначение	Размеры (мм)		
		T	L	G1
	NUT ER20 SHORT	22	10.7	M25x1.5
	ER32 SHORT	36	15.0	M40x1.5
	ER40 SHORT	46	16.0	M50x1.5

TSKN

Зажимная гайка

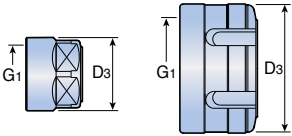
	Обозначение	Размеры (мм)		Рис.
		D3	G1	
	TSKN 6	20	M15x1.0	1
	10	28	M21.5x1.0	1
	16	40	M32x1.5	2
	25	55	M45x1.5	2

PS SK-DIN

Штрель DIN69872 с захватной головкой JIS6339

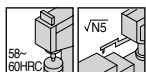
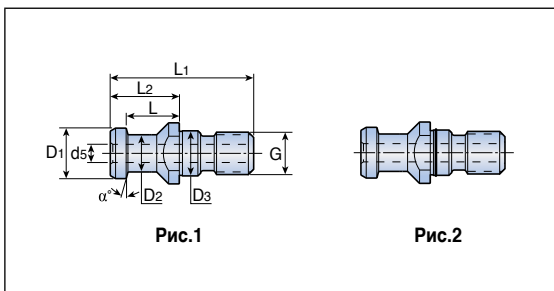

Обозначение	Размеры (мм)										Рис.
	G	D1	D2	D3	d5	L	L1	L2	α°		
PS SK30 15° M12 DIN	M12	13.00	9.0	13	-	19.00	44.0	24.00	15	1	
PS SK40 15° M16 DIN	M16	19.00	14.0	17	-	20.00	54.0	26.00	15	1	
15° M16 DIN O	M16	19.00	14.0	17	-	20.00	54.0	26.00	15	2	
15° M16 DIN B	M16	19.00	14.0	17	7.00	20.00	54.0	26.00	15	1	
15° M16 DIN OB	M16	19.00	14.0	17	7.00	20.00	54.0	26.00	15	2	
PS SK50 15° M24 DIN	M24	28.00	21.0	25	-	25.00	74.0	34.00	15	1	
15° M24 DIN O	M24	28.00	21.0	25	-	25.00	74.0	34.00	15	2	
15° M24 DIN B	M24	28.00	21.0	25	11.50	25.00	74.0	34.00	15	1	

- Отверстия СОЖ только в штрелях с пометкой "B"
- Рис. 2: С наружным уплотнительным кольцом

PS OTT BT/SK

Штрель, система OTT

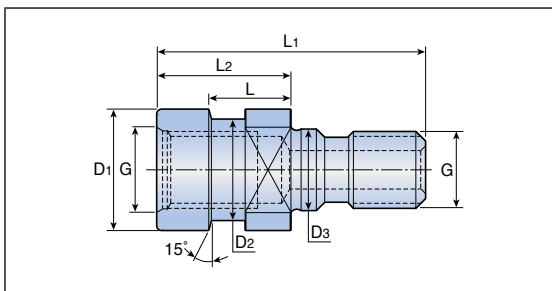

Обозначение	Размеры (мм)						
	G	D1	D2	D3	L	L1	L2
PS OTT BT40 M16	M16	25.0	21.1	17	16.60	56	28
BT50 M24	M24	39.3	32.0	24	13.35	65	25
SK40 M16	M16	25.0	21.1	17	13.60	53	25

PS BT-JIS/MAZAK

ANSI - метрический для станков MAZAK

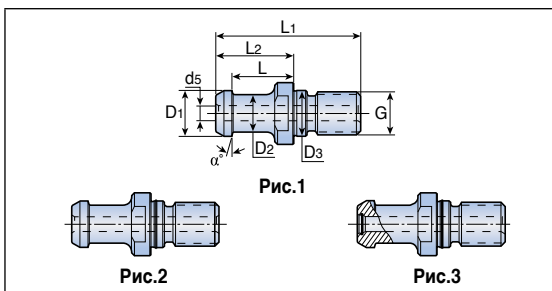

Обозначение	Размеры (мм)									Рис.
	G	D1	D2	D3	d5	L	L1	L2	α°	
PS BT30 15° M12 JIS B	M12	12.00	8.00	13	4.0	18.400	43.0	23.4	15	1
BT40 15° M16 JIS B	M16	19.00	14.00	17	5.5	23.000	54.0	29.0	15	1
BT40 15° M16 JIS O B	M16	19.00	14.00	17	5.5	23.000	54.0	29.0	15	2
BT40 15° M16 JIS O B O	M16	19.00	14.00	17	5.5	23.000	54.0	29.0	15	3
BT50 15° M24 JIS B	M24	28.00	21.00	25	8.0	25.000	74.0	34.0	15	1
BT50 15° M24 JIS O B	M24	28.00	21.00	25	8.0	25.000	74.0	34.0	15	2
BT50 15° M24 JIS O B O	M24	28.00	21.00	25	8.0	25.000	74.0	34.0	15	3
BT40 45° M16 MAZAK B	M16	18.79	12.45	17	7.0	14.026	44.1	19.1	45	1
BT50 45° M24 MAZAK B	M24	28.95	20.83	25	8.0	17.580	65.2	25.2	45	1

- Рис. 1: Отверстия СОЖ только в штрельях с пометкой "B"
- Рис. 2: С наружным уплотнительным кольцом и отверстием под СОЖ
- Рис. 3: С наружными и внутренними уплотнительными кольцами и отверстием под СОЖ

SR-DIN

Стопорный винт DIN1835 В/Е для патрона Weldon

	Обозначение	Размеры (мм)		
		G	L	Используется для хвостовиков
	SR M6x10 DIN 1835-B	M6	10	6
	M8x10 DIN 1835-B	M8	10	8
	M10x12 DIN 1835-B	M10	12	10
	M12x16 DIN 1835-B	M12	16	12, 14
	M14x16 DIN 1835-B	M14	16	16
	M16x16 DIN 1835-B	M16	16	20
	M18x2x20 DIN 1835-B	M18x2	20	25
	M20x2x20 DIN 1835-B	M20x2	20	32, 40
	M24x2x25 DIN 1835-B	M24x2	25	50

PRESET ER-JET

Регулировочный винт с отверстием для СОЖ под цанги ER

	Обозначение	Размеры (мм)	Рис.
		G1	
	PRESET ER-JET 8x1.25	M8x1.25	1
	10x1.5	M10x1.5	1
	12x1.75	M12x1.75	1
	12x1.75L	M12x1.75	2
	16x2	M16x2	1
	16x2L	M16x2	2
	18x1.5	M18x1.5	1
	18x1.5L	M18x1.5	2
	22x1.5	M22x1.5	1
	22x1.5L	M22x1.5	2
	28x1.5	M28x1.5	1

Рис.1

Рис.2

M-CLAMP SCREW SEM

Стопорный болт DIN6367 для оправки под торцевые фрезы

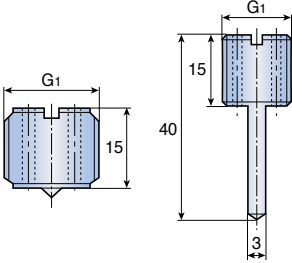
	Обозначение	Размеры (мм)				
		S.M.C	G	D2	K	L
	M8 CLAMP SCREW SEM 16	16	M8	20	6	16
	M10 CLAMP SCREW SEM 22	22	M10	28	7	18
	M12 CLAMP SCREW SEM 27	27	M12	35	8	22
	M16 CLAMP SCREW SEM 32	32	M16	42	9	26
	M20 CLAMP SCREW SEM 40	40	M20	52	10	30
	M24 CLAMP SCREW SEM 50	50	M24	63	12	36

MBA M

Стопорный болт для FMA

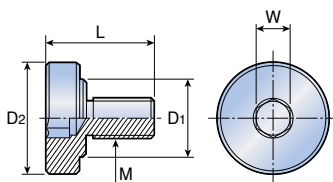

Обозначение	Размеры (мм)				
	M	D2	D1	L	W
MBA M8	M8x1.25	20	15	24	6
M10	M10x1.5	28	18	28	8
M12	M12x1.75	33	23	32	10
M16	M16x2.0	40	23	40	14
M20	M20x2.5	50	27	50	17
M24	M24x3.0	65	37	60	19

• Ключ для винта MBA L-W

WRENCH M-SEMC

Ключ для комбинированного патрона SEMC DIN6368



Обозначение	Размеры (мм)		
	S.M.C	H	L
WRENCH M8 SEMC 16	16	20	180
M10 SEMC 22	22	25	200
M12 SEMC 27	27	32	225
M16 SEMC 32	32	36	250
M20 SEMC 40	40	40	280
M24 SEMC 50	50	50	315

PRESET SCREW

Регулировочный винт для термо патронов

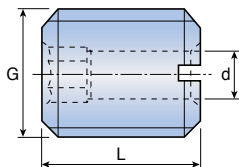

Обозначение	Размеры (мм)				
	G	L	d	Используется для хвостовиков Ключ Неу	
PRESET SCREW M5x20 B	M5	20	2.1	EM E / SRKIN	2.5
M6x20 B	M6	20	2.5	EM E / SRKIN	3.0
M8x20 B	M8	20	3.5	EM E / SRKIN	4.0
M10x18 B	M10	18	4.5	EM E / SRKIN	5.0
M12x18 B	M12	18	5.5	EM E / SRKIN	6.0
M16x20 B	M16	20	7.5	EM E / SRKIN	6.0
M16x25 B	M16	25	7.5	SRKIN	6.0
M20x20 B	M20	20	6.0	EM E	6.0

D-RING SEMC

Передаточное кольцо для комбинированных патронов SEMC

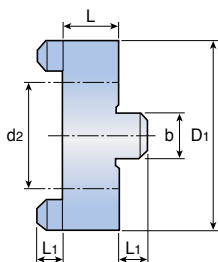

Обозначение	Размеры (мм)				
	b	d2	D1	L	L1
16 D · RING SEMC	8	16	32	10	5.0
22 D · RING SEMC	10	22	40	12	5.6
27 D · RING SEMC	12	27	48	12	6.3
32 D · RING SEMC	14	32	58	14	7.0
40 D · RING SEMC	16	40	70	14	8.0
50 D · RING SEMC	18	50	90	16	9.0

COOLING TUBE HSK A

Трубка охлаждения

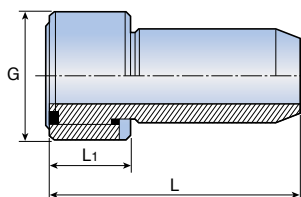

Обозначение	Размеры (мм)		
	L	L1	G
COOLING TUBE HSK A 50	32.7	9.5	M16x1
HSK A 63	36.0	11.5	M18x1
HSK A 80	36.6	13.5	M20x1.5
HSK A 100	43.6	15.5	M20x1.5

WRENCH COOL TUBE HSK A

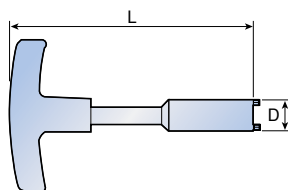

Ключ трубки охлаждения



Обозначение	Размеры (мм)	
	D	L
WRENCH COOL TUBE HSK A 50	15.0	120
HSK A 63	17.0	122
HSK A 83	18.5	186
HSK A 100	22.0	141

WRENCH ER-MINI/SHORT/CLICKIN

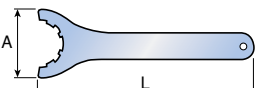
Ключ ER

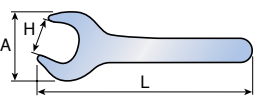
DIN6499	Обозначение	Размеры (мм)		
		A	H	L
 <p>Ключ ER 25, 32, 40, 50</p>	WRENCH ER11 MINI	16.8	-	95
	ER11	32.0	17	95
	ER16 MINI	22.5	-	117
 <p>Ключ ER 11, 16, 20, 25 MINI</p>	ER16	42.8	25	143
	ER20 MINI	28.0	-	128
	ER20	53.5	30	172
	ER25 MINI	29.0	-	120
	ER25	70.0	-	207
	ER32	78.0	-	255
 <p>Ключ ER 11, 16, 20, SHORT, CLICKIN</p>	ER40	95.0	-	285
	ER50	110.0	-	350
	ER32 SHORT	75.0	36	303
	ER40 SHORT	94.0	46	378
	ER32 CLICKIN 27	57.0	27	239
	ER32 CLICKIN 32	67.0	32	273

WRENCH ER11 SMS

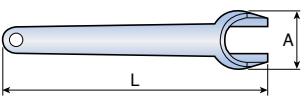

Ключ ER11

	Обозначение	Размеры (мм)	
		A	L
	WRENCH ER11 SMS	22	100

SPANNER TMC

Ключ для фрезерного патрона

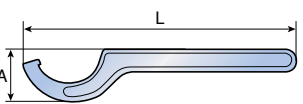
	Обозначение	Размеры (мм)	
		L	A
	SPANNER TMC 20	84.1	15.8
	TMC 25	94.3	18.1
	TMC 32	109.1	21.7
	TMC 42	108.0	23.2

TSKS

Ключ для цанговых патронов TSK



Рис.1



Рис.2

Обозначение	Размеры (мм)			Рис.
	H	L	C1	
TSKS - 6	18.0	174	-	1
10	25.4	177	-	1
16	39.0	225	40	2
25	52.0	228	55	2

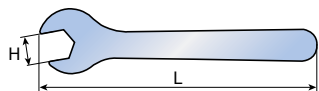
WRENCH DIA 3.2X45

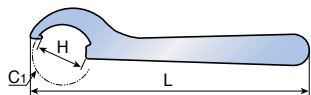

Зажимной ключ

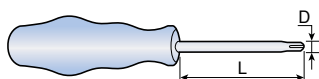

Обозначение	Размеры (мм)	
	D	L
WRENCH DIA 3.2X45	Ø3.2	45

TJS TSD DISPLAY



Дисплей оборотов вращения шпинделя TYPHOON

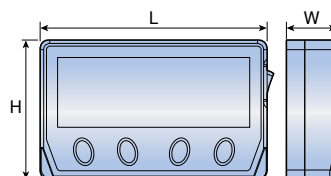

Обозначение	Размеры (мм)		
	L	H	W
TJS TSD DISPLAY	130	80	29

IND ER11 TOOL ADAPTER



Термоусадочный цанговый адаптер ER11 для устройства индукционного нагрева

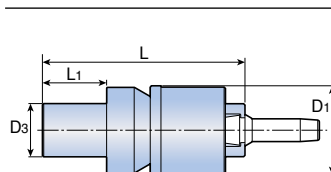

Обозначение	Размеры (мм)			
	D1	D3	L	L1
IND ER11 TOOL ADAPTER	33.2	19.9	75.7	24

TOOL CLAMP-ROTARY/FIX

Устройство установки инструмента - ISO, DIN9871, BT MAS-403

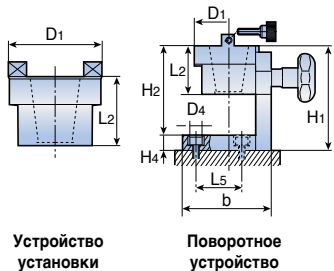

Обозначение	Размеры (мм)									
	CSI	b	D1	D4	L2	H1	H2	H4	L5	
TOOL CLAMP 30 ROTARY	ROTARY	104	70	12.5	56	128	109	19	40	
40 ROTARY	ROTARY	104	82	12.5	56	128	109	19	40	
50 ROTARY	ROTARY	104	103	12.5	71	170	151	19	85	
30 FIX	FIX	-	82	-	58	-	-	-	-	
40 FIX	FIX	-	82	-	58	-	-	-	-	
50 FIX	FIX	-	103	-	71	-	-	-	-	

MULTI CLAMP-E/F, A/C

Поворотное устройство установки инструмента - для хвостовика HSK

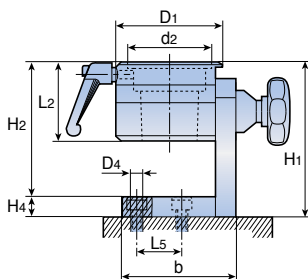

Обозначение	Размеры (мм)									
	CSI	b	d2	D1	D4	L2	L5	H1	H2	H4
MULTI CLAMP 40E/F	40	144	40	113.2	12.5	40	40	133	114	19
50E/F	50	144	50	113.2	12.5	40	40	133	114	19
63E/F	63	144	63	113.2	12.5	40	40	133	114	19
50 A/C	50	104	50	82.0	12.5	40	40	142	123	19
63 A/C	63	104	63	95.0	12.5	40	40	142	123	19
100 A/C	100	144	100	130.0	12.5	85	85	178	159	19

MULTI CLAMP C

Поворотное устройство установки инструмента - для хвостовика C-ADAPTER

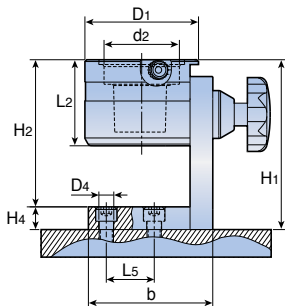

Обозначение	Размеры (мм)									
	SS	b	d2	D1	D4	L2	L5	H1	H2	H4
MULTI CLAMP C6	63	104	63	95	12.5	72	40	142	123	19

EASYLOCK T.C EU

Выбрать нужный размер ключа.
Установить его в паз ключа.

Поместить ключ на гайку
цангового патрона

Установить цанговый
патрон в гнездо

Регулировка
крутящего момента

Индикатор

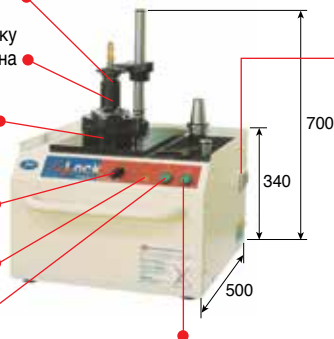

Убедитесь в том, что главный
выключатель включен, а силовой
кабель подсоединен к устройству

■ Спецификации

- Двигатель: Фаза 200/240В, 50/60Гц(1HP)
- Шпиндель: Хвостовик #40, 50
HSK 63, 100
- Вес: Настольная модель - 85 кг.
Тележка (Опция) - 15 кг

Чтобы отсоединить -
Нажмите и удерживайте кнопку
"unlock" до тех пор, пока цанговый
патрон не откроется полностью

Чтобы соединить -
Нажмите и удерживайте кнопку
"clamp" до тех пор, пока цанговый
патрон полностью не откроется

Примечание: Сборка цанги и режущего инструмента. Вручную поместите гайку на цанговый патрон.

Обозначение	TaeguTec №	Комплектующие	
		Стандарт	Опция
EASYLOCK T.C EU	4651108	TP50 AD 40 EASY	EASY LOCK TROLLEY
		WRENCH ER16 EASY LOCK	TP40 AD 30 EASY
		WRENCH ER20 EASY LOCK	TP50 AD HSK 63 EASY
		WRENCH ER25 EASY LOCK	TP50 AD HSK 100 EASY
		WRENCH ER32 EASY LOCK	WRENCH ER50 EASY LOCK
		WRENCH ER40 EASY LOCK	WRENCH TG100 OPEN EASY

EASYLOCK TROLLEY

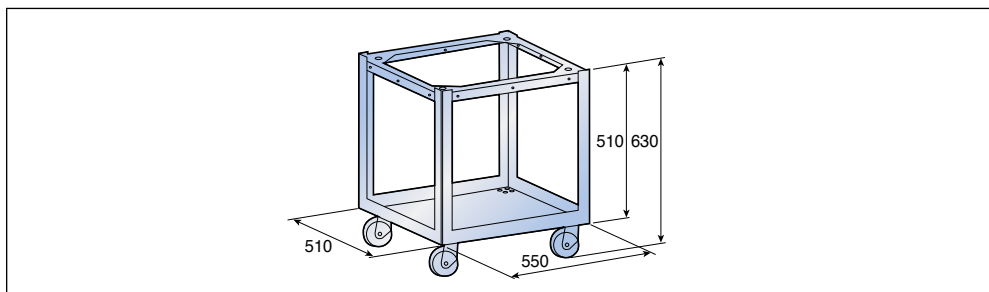

Обозначение	TaeguTec №
EASYLOCK TROLLEY	4651109

Индукционное нагревательное устройство



Техническая спецификация	
Диапазон зажима	3-32мм Твердосплавный хвостовик
Диапазон зажима	6-32мм
Основной источник питания	3x380 - 500В 50/60Гц
Номинальная мощность	13кВт
Номинальный ток	16 А
Источник питания охлаждающего устройства	220В 50Гц
Номинальная мощность	0.5кВт
Макс. длина инструмента	440мм (От указателя)
Макс. диаметр зажимного патрона	52мм
Эффективная длина индукционного поля	45мм
Время нагрева	5-12 секунд
Время охлаждения	50-90 секунд
Вес	150кг
Габаритные размеры	170x73x60см



Основной рабочий пост
post #50,
HSK 100

Инструментальный
переходник #40,
HSK 63



Корпус
охлаждения

Лоток для
режущих
инструментов

Контрольная
панель

Ящик для
инструментов

Витки катушки

Основное
индукционное
устройство



Устройство индукционного нагрева
4654106 IND SHRINK START UNIT EUR

- Без охлаждающего устройства

TaeguTec №	Обозначение	Включает
4652264	IND SHRINKIN UNIT EUR	Устройство индукционного нагрева, охлаждающее устройство, тележку, три инструментальных переходника

Втулки охлаждения	используются для
IND COOLING COLLET 6-8	
10-12	SRKIN
14-16	SRKIN
18-20	SRKIN
ER 3-5	SRK
ER 6	SRK
ER 8	SRK
ER 10	SRK
ER 12	SRK

Дополнительный инструментальный переходник под HSK

IND 32 HSK TOOL ADAPTER

40 HSK TOOL ADAPTER

50 HSK TOOL ADAPTER⁽¹⁾

63 HSK TOOL ADAPTER

80 HSK TOOL ADAPTER

- ⁽¹⁾ Для конуса #30



■ Устройство электрического нагрева

ТаeguTec №	Обозначение
4651950	SHRINKIN UNIT V2 EUR

220V 50/60 HZ

- В комплекте поставки входит ручной нагревательный элемент 220В V2.0

- Подходит для цанговых патронов ER...SRK, ER...SRF

■ Рукоятка переносного нагревательного устройства

ТаeguTec №	Обозначение
4651952	HEATING HANDLE 220V V2

► T-SHRINK / комплект цанг ER32

■ комплект цанг ER32 T-SHRINK 6 штук

Обозначение	Размер цанги
SET ER32 SRK S 6 EUR	4, 5, 6, 8, 10, 12
SRK M 6 EUR	4, 5, 6, 8, 10, 12
SRK L 6 EUR	4, 5, 6, 8, 10, 12



■ Устройство электрического нагрева T-SHRINK с комплектом цанг ER32 T-SHRINK 6 (4-12)

Обозначение	Питание	Размер цанги
KIT SHRINKIN S V2 EUR	220V 50/60 HZ	4, 5, 6, 8, 10, 12
M V2 EUR	220V 50/60 HZ	4, 5, 6, 8, 10, 12



Техническое руководство

► Герметичные цанги для подвода СОЖ через инструмент

■ Применение

Цанги ER используются для операций, требующих подвода СОЖ через инструмент, а также для стандартных инструментов таких как сверла, расточные державки, концевые фрезы, развертки, метчики и специальные инструменты.

Цанги ER обеспечивают точную эффективную подачу СОЖ.

Цанги применяются на высокоскоростных станках с подачей СОЖ через шпиндель/револьверную головку. Они обеспечивают максимальную производительность, высокие скорости резания, хорошую стойкость инструмента и высокое качество обработанной поверхности.

■ Особенности

- Высокоточные герметичные цанги со стягиваемостью 1.00мм и возможностью подвода СОЖ через инструмент
- Повышение эффективности обработки
- Увеличение стойкости инструмента
- Сильный зажим
- Защита от загрязнений
- Быстрое удаление стружки с заготовки

■ Преимущества

- Подача СОЖ под высоким давлением до 100 бар
- Устраняет препятствия для подачи СОЖ

■ Примечания

- Для максимальной надежности и усилия зажима хвостовик режущего инструмента должен быть установлен в цангу на глубину минимум 2 диаметра хвостовика
- Сопло для подачи СОЖ цанги JET2 необходимо направить непосредственно на режущую кромку инструмента
- Подходит для всех стандартных хвостовиков

► Герметичные цанги для подвода СОЖ через инструмент ER coolit

■ 2 типа



Герметичная цанга JET 1

Для инструментов с цилиндрическим хвостовиком и отверстием для подвода СОЖ



Герметичная цанга JET 2

Два наклонных сопла. СОЖ подается на режущую кромку - Для инструментов с цилиндрическим хвостовиком (без отверстия для СОЖ)

► Хвостовики

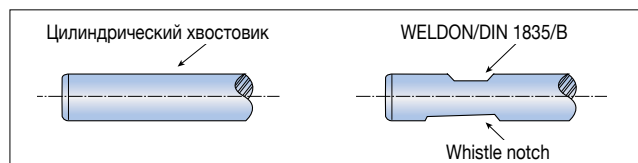

Техническое руководство

► ER - зажимная гайка DIN6499

■ Описание

Гайка ER с подшипником скольжения - уникальная конструкция из двух частей, обеспечивающая радиальное и угловое самоцентрирование.

■ Особенности

- Уникальный подшипник скольжения из двух частей
- Радиальное и угловое перемещение для лучшей concentricity
- Усилие зажима на 50-100% выше, чем у стандартных гаек ER благодаря подшипнику скольжения
- Сбалансирована для работы на высоких оборотах
- Компактный дизайн: общие параметры и диапазон размеров как у стандартной гайки для герметичной цанги

■ Установка

Вставьте цангу в гайку до установки в цанговый патрон

■ Последовательность установки

Вставьте цангу под наклоном, попадая двумя выступающими зубцами (A) в канавку цанги (B).

Разместить гайку и цангу на чистой горизонтальной поверхности.

Надавить пальцем на цангу сверху до ее защелкивания (C).

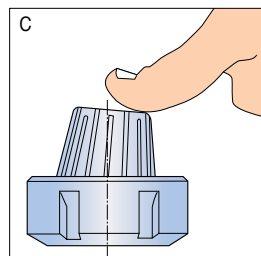
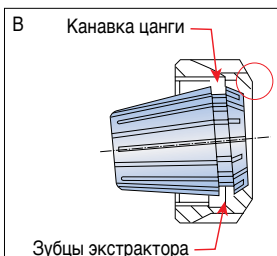
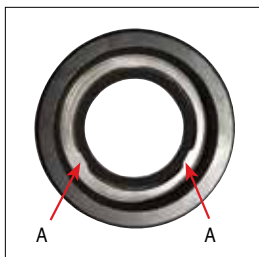

■ Важно

Никогда не вставляйте цангу параллельно кольцу экстрактора. Это может привести к поломке зубцов экстрактора. При разжиме гайки цанга свободно выводится из патрона при помощи зубцов экстрактора.

Техническое руководство

► ER - зажимная гайка DIN6499

■ Последовательность разборки

- 1 Совместите выгравированный значок на серебристом кольце (D) с любым пазом (E) на гайке.
- 2 Разместите гайку с цангой лицевой поверхностью вниз на чистой горизонтальной поверхности.
- 3 Вставьте отвертку вертикально между пазами гайки и цанги с обратной стороны выгравированного значка (D).
- 4 Наклоните отвертку наружу и надавите на цангу в противоположном направлении (F).

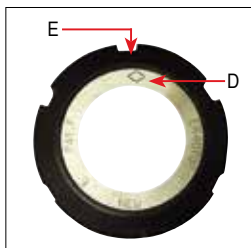

Примечание:

Для максимальной эффективности поверхность зажимной гайки и конус цанги должны быть чистыми и смазанными перед использованием.

Рекомендованный момент затяжки для стандартных гаек ER и гаек с подшипником скольжения ER-Top.

Тип гайки	Кг х м
ER-11	5
ER-11M	3
ER-16	7
ER-16M	4
ER-20	12
ER-20M	8
ER-25	20
ER-32	22
ER-40	25
ER-50	35

Важно:

Момент затяжки рассчитан для максимального диаметра каждой цанги. Момент необходимо постепенно уменьшать при использовании хвостовика меньшего размера.

Техническое руководство

▶ Цанговый патрон TSK

■ Особенности и преимущества

- Отличная точность и хорошее усилие зажима благодаря небольшому углу конуса (цанга ER: 8°, цанга TSK: 4°)
- Тонкая конструкция для глубокой обработки и обработки впадин
- Подходит для высокоскоростной обработки
- Различные типы цанг TSK (обычные и с подводом СОЖ)
- Универсальная обработка сверлами и концевыми фрезами

■ Применение

- Универсальная обработка сверлами и концевыми фрезами
- Высокоскоростная обработка пресс-форм и штампов
- Прецизионная обработка развертками и концевыми фрезами

■ Как собрать цангу с гайкой



a. Приспособление для сборки
(в комплекте)



b. Гайка



c. Цанга

❶ Вставить задний конец цанги (c) в приспособление (a)



❷ Вставить соединенную часть (a+c) в гайку (b)



❸ Отсоединить приспособление (a) от остальной части (b+c)



Техническое руководство

► HSK (DIN69893)

- Особенности
- Стандарт DIN
- Для высокоскоростной обработки
- Размеры: #32, 40, 50, 63, 100
- Для станков с автоматической и ручной сменой инструментов
- Двойной контакт с конусом и торцом шпинделя
- Высокая жесткость

► Радиальная жесткость различных конусов шпинделя

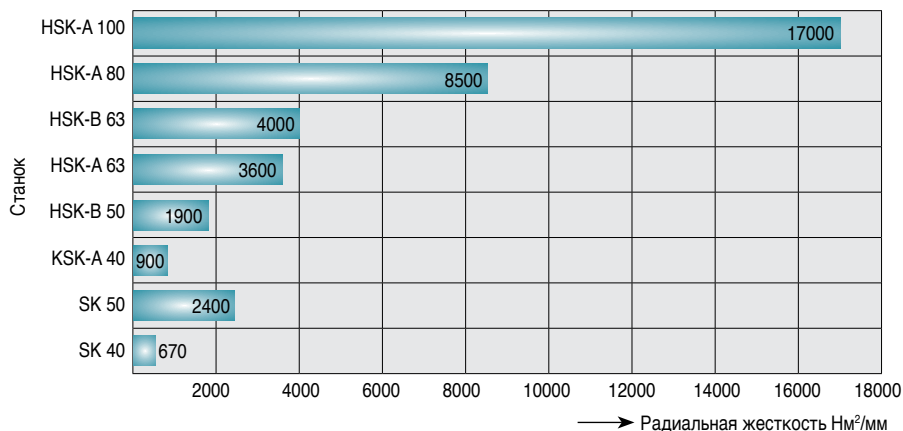

► Тип

- Тип A: для автоматической смены инструментов

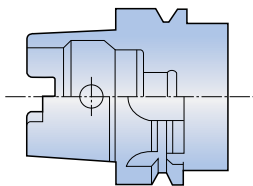

- Тип В: с внутренним подводом СОЖ через торец

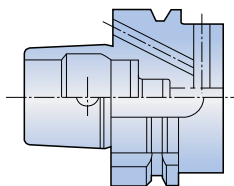

- Тип С: ручной зажим

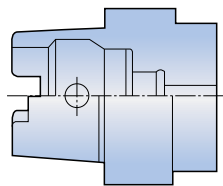

- Тип D: с внутренним подводом СОЖ через торец

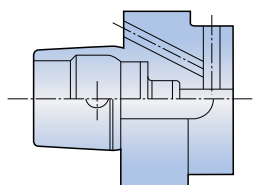

- Тип E: для высокоскоростной обработки

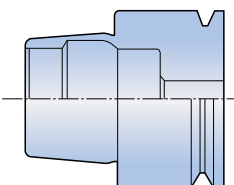

- Тип F: для сверх высокоскоростной обработки

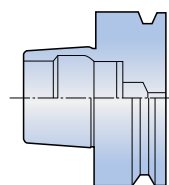

Техническое руководство

► Фрезерный патрон

- Исключительное усилие зажима и простая эксплуатация

- Момент

Тип	Момент (кгс•м)
TMC 25	160
TMC 32	300
TMC 42	500

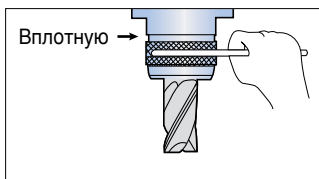
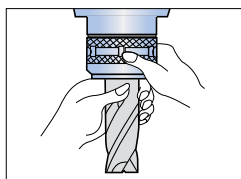

Затяните гайку вплотную к оправке (избегайте рывков)

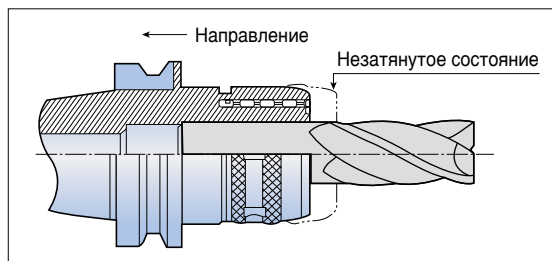

- Улучшенная точность повышает стойкость инструментов

Точность и низкое биение достигаются за счет прецизионной шлифовки и специального разрезного элемента для исключения повреждений и деформации инструментов.

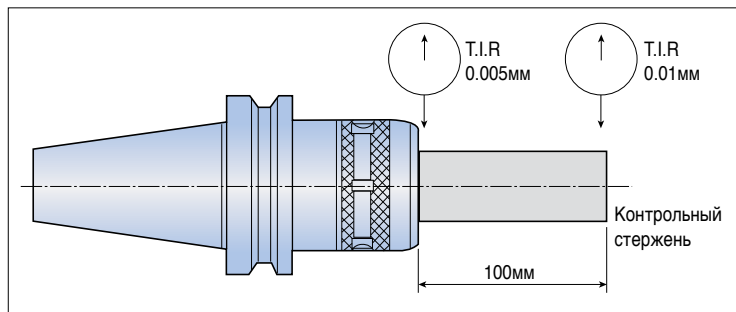

Техническое руководство

Повышенная жесткость

Повышенная жесткость и прочность корпуса благодаря увеличению толщины корпуса. Это достигается за счет специального разрезного элемента.

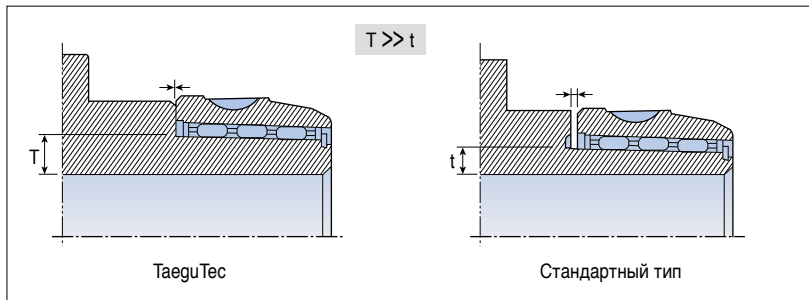

Отличная износостойкость

Отличная износостойкость благодаря распределению давления на поверхность ролика за счет увеличенного количества роликов в специальном элементе.

Тип	TaeguTec	A Co.	B Co.
Ø32	60	55	60
Ø42	75	72	72

<Количество роликов в одном ряду>

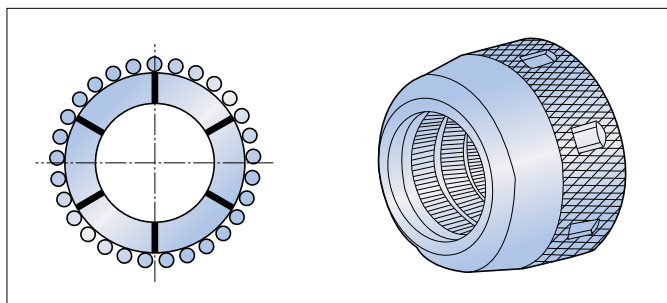

► Система быстрой смены инструмента

- DIN 69871
HSK
BT MAS 403

- Преимущества системы T-CLICK
 - Контакт по торцу и конусу
 - Идеальное решение для высокоскоростной обработки
 - Высокая точность, низкое биение
 - Отличная жесткость
 - Быстрый и легкий зажим



- Преимущества быстрой смены инструмента
 - Быстрая смена инструмента: конический хвостовик и патрон соединяются за пол оборота
 - Отсутствие теплового удара по конусу оправки
 - Разнообразие диаметров и длин
 - Не требуется использовать удлинитель
 - Не нужны запасные части
 - Доступны заготовки T-CLICK для изготовления оснастки покупателем
 - Зажим монолитного твердосплавного инструмента термоусадкой
- Момент затяжки: 235Н·м

G2.5
20,000 RPM

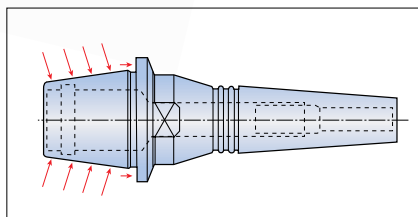
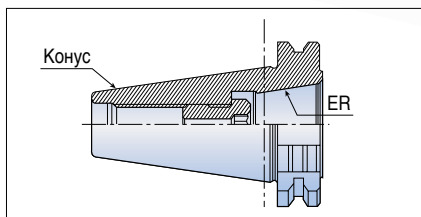

► Балансируемые цанговые патроны

- Высокоточный баланс с прямым снятием показаний благодаря высокоточным балансировочным кольцам
- Простой порядок балансировки на всех типах балансировочных машин
- Статическая и динамическая балансировка



■ Инструкции по эксплуатации

Данный метод необходимо корректировать в соответствии с используемой балансировочной машиной.

- ❶ Ослабить 3 стопорных винта на опорном кольце (синего цвета).
Совместить 2 балансировочных кольца (золотистого цвета) в положении "0" на опорном кольце. После настройки колец затянуть 3 стопорных винта.
- ❷ Вставить цанговый патрон в шпиндель и затянуть его с помощью штривеля.
Вставить режущий инструмент в цанговый патрон, настроить необходимый вылет и закрепить его.
- ❸ Ввести необходимые параметры в балансировочную машину: класс точности балансировки (G), частоту вращения (об/мин.) и т.д.
- ❹ Протестировать цанговый патрон в сборе на балансировочной машине.
Отметьте результаты для ориентации угла дисбаланса и г х мм значение дисбаланса.
- ❺ Ослабить 3 стопорных винта на опорном кольце и выровнять 2 балансировочных кольца по замеренному значению дисбаланса. Вращать оба балансировочных кольца до угла дисбаланса на опорном кольце (или до лазерной отметки на балансировочной машине с лазерным индикатором). Затянуть стопорные винты.
- ❻ Протестировать цанговый патрон в сборе еще раз и проверьте результаты.

- **Примечание: Показания должны быть в пределах допуска.**

- Если необходимый баланс достигнут на балансировочной машине инструмент готов для использования. Если баланс не в допуске необходимо выполнить одну из следующих операций:

- Первый способ

- а) Если дисбаланс в пределах 0-3 г х мм и $\pm 20^\circ$ от исходного угла,
Тогда увеличьте начальное значение г х мм на балансировочных кольцах в соответствии с показаниями на машине, не меняя исходное угловое положение.

- Второй способ

- а) Если дисбаланс в пределах 0-3 г х мм, а угол примерно 180° от исходного угла,
Тогда снизьте начальное значение г х мм на балансировочных кольцах в соответствии с показаниями на машине, не меняя исходное угловое положение.

- Третий способ

- а) Если дисбаланс менее 1 г х мм, а угол $20-90^\circ$ от исходного угла,
Тогда вращайте оба балансировочных кольца примерно на 5° в указанном направлении.

- Четвертый способ

- а) На некоторых балансировочных машинах возможно отрегулировать дисбаланс, вращая точку максимума, указанную на балансировочных кольцах до необходимого углового положения.

Положение "0" к балансу G2.5 20K



Точка максимума

► Гидравлический патрон

■ Особенности и преимущества

- Постоянное усилие захвата
- Отличная точность (биение до 5мкм)
- Удобная и безопасная смена инструмента с помощью крепежного винта
- Возможно использовать прямые цанги ТНС (обычные и с подводом СОЖ)

■ Применение

- Точная обработка
 - а) чистовое фрезерование, развертывание, чистовое растачивание
- Сверление: твердосплавные сверла небольших диаметров
 - а) Для алюминия или чугуна

■ Эксплуатация

- Закрепление инструмента
 - а) Вставьте хвостовик инструмента между $L_{\text{макс.}}$ и $L_{\text{мин.}}$ (рис. 1) и поверните крепежный винт по часовой стрелке до упора.
- Извлечение инструмента
 - а) Для извлечения инструмента из гидравлического патрона поверните крепежный винт против часовой стрелки на 5-6 оборотов и достаньте инструмент.

- Примечания

- а) Удалите смазку, СОЖ и грязь с внутреннего посадочного отверстия гидравлического патрона и хвостовика инструмента перед установкой.
- б) Обеспечьте минимальную длину зажима $L_{\text{мин.}}$ (см. рис. 1 и табл. 1)
- с) С цангой должны использоваться только инструменты с цилиндрическим хвостовиком с допуском h6 (табл. 2) и Ra мин.=0.3мкм (шлифованные) и хвостовиком Weldon
- д) Извлеките инструмент из гидравлического патрона, когда он не используется длительное время.
- е) Не поворачивайте крепежный винт до установки инструмента в гидравлический патрон.

* Обратите внимание на информацию в таблицах ниже

Рисунок 1. Конструкция оправки



Таблица 1. Рекомендованная минимальная и максимальная длина (L) закрепления концевой инструмент

Внутренний посадочный диаметр Ø (мм)	Lмин. (мм)	Lмакс. (мм)
6	27.5	37.5
8	27.5	37.5
10	32.5	42.5
12	37.5	47.5
14	37.5	47.5
16	42.5	52.5
20	42.5	52.5
25	51.0	61.0
32	55.0	65.0

Таблица 2. Диапазон допуска h6

Размер хвостовика Ø (мм)		Диапазон допуска h6 (µm)
	3	0
		-6
3	6	0
		-8
6	10	0
		-9
10	18	0
		-11
18	30	0
		-13
30	50	0
		-16

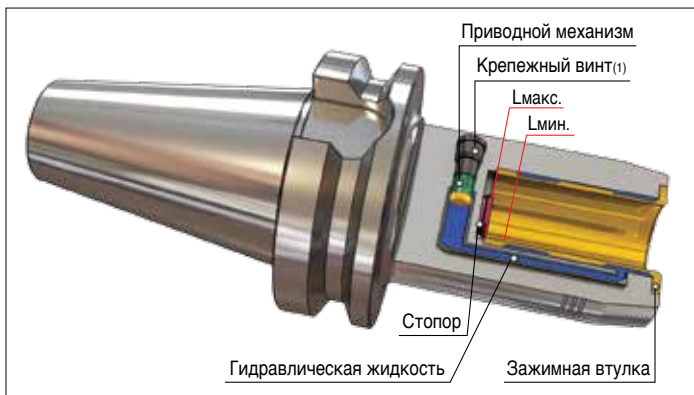
Таблица 3. Момент зажима

Внутренний посадочный диаметр Ø (мм)	Момент зажима (Н·м)
6	10
8	25
10	40
12	65
14	90
16	120
20	240
25	260
32	450

► Система термозажима T-SHRINK



► Система термозажима T-SHRINK

Цанговые патроны с термозажимом T-SHRINK ER - это расширение технических возможностей существующей популярной системы ER. Цанги T-SHRINK используют принцип термической усадки для жесткого зажима монолитных фрез. Данная новая система обеспечивает больший момент, точное биение и повторяемость. Цанги T-SHRINK с различными вылетами позволяют обрабатывать более глубокие канавки и выполнять фрезерование узких мест. TaeguTec предлагает комплексную систему цанг T-SHRINK ER, включая уникальное устройство нагрева с переносной рукояткой. Устройство оснащено высокотехнологичной системой контроля температур для удобного использования на обрабатываемом центре или в инструментальном цехе.



■ Только для монолитных инструментов



L(мм)	Макс. T.I.R
35	7 μm
60	9 μm
85	10 μm

■ Особенности

- Тонкая конструкция для максимальной эффективности и доступа
- Гибкость: подходит для стандартных патронов ER
- Передача большого момента
- Жесткий зажим монолитного инструмента
- Высокая точность, низкое биение
- Отличная повторяемость
- Демпфирование вибраций
- Подходят цанги с отверстием для СОЖ JET2
- Симметричный дизайн для высокоскоростной обработки
- Быстрая и легкая смена инструмента
- Уникальное устройство нагрева T-SHRINK с переносной рукояткой.

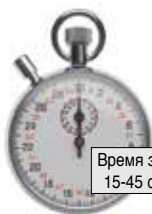

Время зажима
15-45 секунд

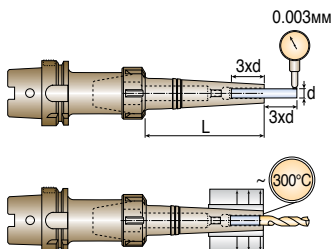

► Патроны для метчиков GTI

■ Описание

Укороченные патроны под метчики для цанг ER



■ Применение

Осевые-плавающие/натяжные/компрессионные типы патронов для фрезерных станков с ЧПУ и токарных станков с реверсивным двигателем и жестким толчковым перемещением

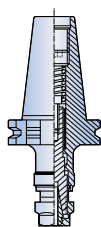

DIN 69871

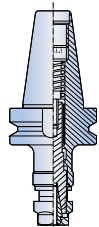

BT MAS-403

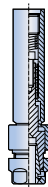

Цилиндрический
хвостовик

■ Особенности

- Компенсация отклонений подачи станка и шага резьбы
- Плавающий механизм компенсирует несоосность между метчиком и заготовкой
- Нарезание правой и левой резьбы

■ Преимущества

- Эффективное закрепление метчика при помощи пружинящей цанги ER без использования приводного кулачка
- Компактный дизайн для операций с минимальным зазором
- Конструкция для тяжелых условий обработки обеспечивает высокую точность нарезания резьбы

■ Эксплуатация

Для нарезания резьбы в глухих и сквозных отверстиях

1 Введите значение подачи в зависимости от шага резьбы (или на 1-2% ниже) и установите шпиндель в начальное положение с зазором 0.08мм.

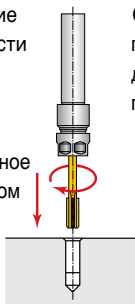

2 Поверните шпиндель по часовой стрелке до достижения необходимой глубины.

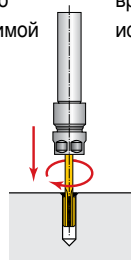

3 Остановите подачу и вращение и вернитесь в исходное положение

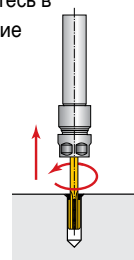

▶ Регулируемые вращающиеся патроны для сверл со сменными пластинами

■ Применение

Для применения на обрабатывающих центрах и сверлильных станках

■ Особенности

- Диапазон регулирования диаметра от -0.30мм to $+1.30\text{мм}$
- Допуск на диаметр отверстия $\pm 0.02\text{мм}$
- Подача СОЖ через хвостовик или фланец (тип "В")
- Давление СОЖ до 70 бар

■ Эксплуатация

Лучшие результаты достигаются при использовании установки для предварительной настройки или аналогичного приспособления.

- Настройте винт А или В.
- Предварительная настройка должна быть на 0.3мм меньше требуемого диаметра
- Затянуть винты А и В
- Выполнить тестовое сверление, измерить размер отверстия и отрегулировать необходимый диаметр
- Окончательная настройка диаметра производится на станке с цифровым индикатором или устройством для настройки

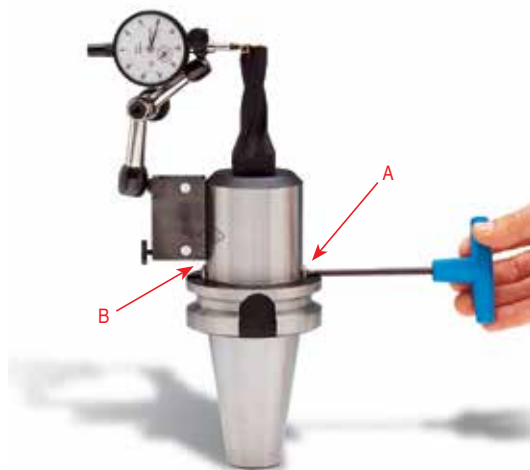

► GYRO - система радиального и углового выравнивания оправок

■ Преимущества

- Легкая регулировка для устранения смещения осей патрона и револьверной головки (сверла и заготовки)
- Точный и эффективный зажим цапгами ER и герметичными цапгами ER Coolit Jet
- Быстрая регулировка на станке при помощи промежуточной втулки и кольцевого калибра

■ Эксплуатация

Инструкция по эксплуатации прилагается к каждому патрону

■ Примечания

- Давление СОЖ должно быть от 10 до 80 бар для сверл небольшого диаметра : диапазон диаметров 3-20мм (обычного давления СОЖ 4 бар недостаточно)
- Необходимо обеспечить хорошую фильтрацию СОЖ, чтобы стружка не забивала отверстия для подачи СОЖ в сверле
- Для обеспечения максимальной эффективности системы GYRO необходимо проверить и настроить в соответствии с характеристиками станка люфт револьверной головки и оси суппорта



► GYRO - система радиального и углового выравнивания оправок

Регулируемые патроны для простого устранения радиальной и угловой несоосности

■ Применение

GYRO - регулируемые патроны для решения проблем при сверлении, нарезании резьбы метчиком и развертывании на токарных станках с ЧПУ и токарно-револьверных станках. Специальный дизайн патронов позволяет легко устранить радиальную и угловую несоосность между патроном и револьверной головкой. Применение системы GYRO позволяет сократить время обработки благодаря возможности обработки отверстий за одну операцию и достижение допуска 0.01мм, исключая необходимость в последующем растачивании или развертывании.

- Существенное улучшение технологии сверления на токарных станках с ЧПУ
- Значительное увеличение производительности обработки при снижении затрат

■ Особенности

- Обеспечивает высокоточное сверление с допуском 0.01мм, что является окончательной операцией обработки отверстий на токарных станках с ЧПУ
- Увеличивает стойкость инструментов в десятикратном размере, особенно при использовании инструментов из быстрорежущей стали, монолитных и напайных сверл, метчиков и разверток
- Позволяет увеличить скорость резания и подачу до 300%
- Подача СОЖ через центр устройства и отверстие для СОЖ в инструменте

